

2/3 Port Valve for Various Fluids Control



■ 2/3 Port Solenoid/Air Operated Valve for Various Fluids Control
(For Water/Air/Oil/Gas/Vacuum/Steam)

□ 2/3 Port Solenoid Valve

- Direct operated 2 port solenoid valve: **VX21/22/23** 17-3-17
- Pilot operated 2 port solenoid valve: **VXD21/22/23** 17-3-33
- Pilot operated 2 port solenoid valve: **VXP21/22/23** 17-3-43
- Water hammer relief, pilot operated 2 port solenoid valve: **VXR21/22/23** ... 17-3-53
- Pilot operated 2 port solenoid valve
for zero pressure differential operation: **VXZ**..... 17-3-61
- Pilot operated 2 port solenoid valve for high pressure: **VXH**..... 17-3-69
- 2 port solenoid valve for dust collector: **VXF**..... 17-3-71
- Direct operated 3 port solenoid valve: **VX31/32/33** 17-3-81

□ 2/3 Port Air Operated Valve

- Direct air operated 2 port valve: **VXA21/22**..... 17-3-93
- Direct air operated 2 port valve: **VXA31/32**..... 17-3-101

The models VX21/22/23 have been revised. For details, please refer to catalog no. ES70-23A.
The models VX31/32/33 have been revised. For details, please refer to catalog no. ES70-26A.
Similar updating for other VX* series are scheduled to follow shortly.

VC□

VDW

VQ

VX2

VX□

VX3

VXA

VN□

LVC

LVA

L VH

LVD

LVQ

LQ

LVN

TI/
TIL

PA

PAX

PB

For Fluid Control

2/3 Port Valve

Solenoid Valve/Air Operated Valve

For Water, Air, Oil, Gas, Vacuum and Steam

2 Port, Direct Operated

Series VX21/22/23

N.C., N.O./ Single unit, Manifold

Refer to our catalog "ES70-23A".

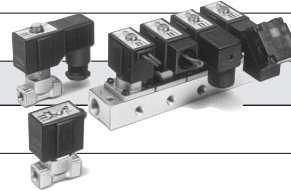

2 Port, Pilot Operated (Diaphragm type)

Series VXD21/22/23

N.C., N.O.

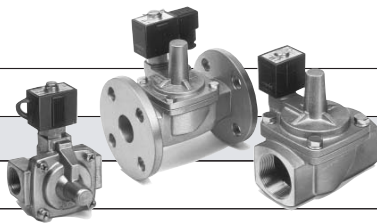
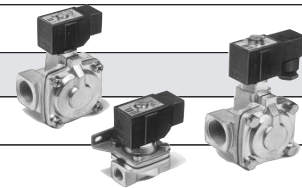

2 Port, Pilot Operated (Disk type)

Series VXP21/22/23

N.C., N.O.

2 Port, Pilot Operated

Series VXR21/22/23

< Water hammer relief > N.C., N.O.

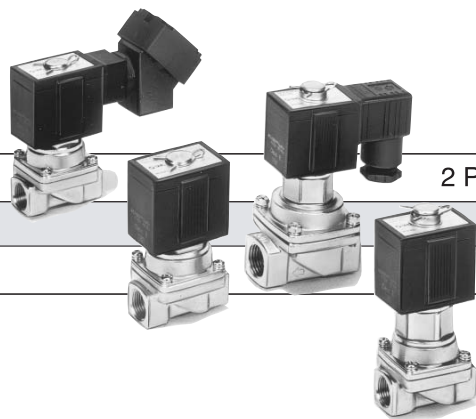
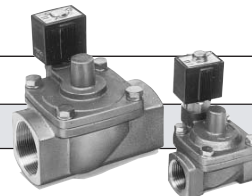

2 Port, Pilot Operated (Diaphragm type, zero pressure differential operation)

Series VXZ22/23

N.C., N.O./ Single unit

The models VX21/22/23 have been revised. For details, please refer to catalog no. ES70-23A. The models VX31/32/33 have been revised. For details, please refer to catalog no. ES70-26A. Similar updating for other VX* series are scheduled to follow shortly.

Solenoid Valves List

Number of ports		2 port									
Action	Direct operated				Pilot operated Diaphragm type		Pilot operated Disk type		Pilot operated <Water hammer relief>		
Series	VX21/22/23				VXD21/22/23		VXP21/22/23		VXR21/22/23		
Body type	Single unit		Manifold		Single unit		Single unit		Single unit		
Valve type	N.C.	N.O.	N.C.	N.O.	N.C.	N.O.	N.C.	N.O.	N.C.	N.O.	
Applicable fluids	Standard	Water	●	—	—	—	●	●	●	—	
		Air	●	●	●	●	●	●	—	—	
		Oil	●	●	●	●	●	●	●	—	
		Low vacuum (1 Torr)	●	●	—	—	—	—	—	—	
	Option	Steam	●	—	—	—	—	●	—	—	
		Medium vacuum (10 ⁻³ Torr)	●	●	—	—	—	—	—	—	
		Non-leak (10 ⁻⁵ atm cc/sec)	●	●	—	—	—	—	—	—	
	High temperature water, High temperature oil	●	—	—	—	●	●	●	●		
Port size	Rc	1/8 (6A)	●	●	—	—	—	—	—	—	
		1/4 (8A)	●	●	—	—	●	—	—	—	
		3/8 (10A)	●	●	—	—	●	—	—	—	
		1/2 (15A)	●	—	—	—	●	●	●	●	●
		3/4 (20A)	—	—	—	—	●	●	●	●	●
	Flange Rc	1 (25A)	—	—	—	—	●	●	●	●	●
		1 1/4 (32A)	—	—	—	—	●	●	●	●	●
		1 1/2 (40A)	—	—	—	—	●	●	●	●	●
		2 (50A)	—	—	—	—	●	●	●	●	●
			—	—	—	—	●	●	●	●	●

Page	Catalog ES70-23A	17-3-17	17-3-27	17-3-37
------	------------------	---------	---------	---------

Air Operated Valves List



* An option is available that sets the orifice in the vacuum side to the maximum bore for exclusive use when used in a vacuum pad application. Refer to page 17-3-86 for details.

Number of ports		2 port				3 port	
Action	Direct operated				Direct operated		
Series	VXA21/22				VXA31/32		
Body type	Single unit		Manifold		Single unit	Manifold	
Valve type	N.C.	N.O.	N.C.	N.O.	C.O.	C.O.	
Applicable fluids	Standard	Water	●	—	—	—	
		Air	●	●	●	●	
		Oil	●	●	●	●	
		Low vacuum (1 Torr)	●	●	●	●	
Option	Medium vacuum (10 ⁻³ Torr)		●		●	●	
	Non-leak (10 ⁻⁵ atm cc/sec)		●		●	●	
Port size	Rc	1/8 (6A)	●	●	—	—	
		1/4 (8A)	●	●	—	—	
		3/8 (10A)	●	●	—	—	
		1/2 (15A)	●	●	—	—	

Page	17-3-45	17-3-49	17-3-53	17-3-57
------	---------	---------	---------	---------

Glossary

Pressure

1. Max. operating pressure differential

This pressure difference is the highest pressure difference allowable to operate (a difference between the pressures in the inlet side and the outlet side) in an open state and the closed state of valve. A case of 0 kgf/cm² in the outlet side results in the highest operating pressure.

2. Min. operating pressure differential

This pressure difference is the lowest pressure difference (a difference between the pressures in the inlet side and the outlet side) required to hold the main valve fully open.

3. Max. system pressure

This pressure is the limit of pressure that can be applied to pipe line. (Line pressure)
[The pressure difference in a solenoid valve must be maintained less than the highest operating pressure difference.]

4. Proof pressure

This is the pressure that can be withstood without deterioration of the performance when valve returns within the range of the operating pressure. (A value under a specified condition.)

Electricity

1. Apparent power (VA)

Volt-ampere is the product of voltage (V) and current (A). Power dissipation (W): For AC, $W = V/A \cos\theta$. For DC, $W = V/A$ (Note) $\cos\theta$ shows power factor.

2. Surge voltage

The surge voltage is a high voltage generated momentarily when cutting the power supply.

3. Hum sound

The hum sound is a noise generated through repeated adsorption and releasing on an armature adsorption surface.

For an AC solenoid, no shading coil releases the spring reaction because of the existence of a 0 point (twice per frequency) of the suction force.

Others

1. Material

NBR: Nitrile rubber

FKM: Fluoro rubber—Trade names: Vitron®, Dai-el®, etc.

EPDM: Ethylene propylene rubber

PTFE: Polytetrafluoroethylene resin—Trade names: Teflon®, Polyflon®, etc.

Polyacetal (POM)—Trade names: Duracon®, Derlin®, etc.

2. Oil preserve treatment

After assembly, valve is put through a parts washer to remove any oil used during assembly.

3. Symbol

The JIS symbol is (☞☞☞☞): this designates the valve to be normally closed.

However, in situations where the secondary pressure exceeds the primary side pressure, the resulting back pressure will cause back flow through the valve.

VC□

VDW

VQ

VX2

VX□

VX3

VXA

VN□

LVC

LVA

LVH

LVD

LVQ

LQ

LVN

TI/
TIL

PA

PAX

PB

Caution

Refer to page 17-6-3 for Safety Instructions and Solenoid Valve Precautions.

The VX* series will be revised shortly.



For details about certified products conforming to international standards, visit us at www.smcworld.com.

Pilot Operated 2 Port Solenoid Valve Zero Pressure Differential Operation For Air, Gas, Vacuum, Water and Oil

Series VXZ

Change of valve type from N.C. ↔ N.O. is simple.

Excellent maintenance feature

Separation of movable iron core and diaphragm valve permits easy disassembly/reassembly.

Diaphragm

Strong against dust and water scale in fluid.

Wide variations enables a wide range of fluids control.

Low power consumption, long service life, and high reliability type molded coil

VXZ22 7.5/6 W (50/60 Hz AC)
VXZ23 11/9.5 W (50/60 Hz AC)

Compact, lightweight and large valve capacity

Zero pressure differential operation

For details about the max. operating pressure difference, refer to page 17-3-63 for Model/Valve specifications.

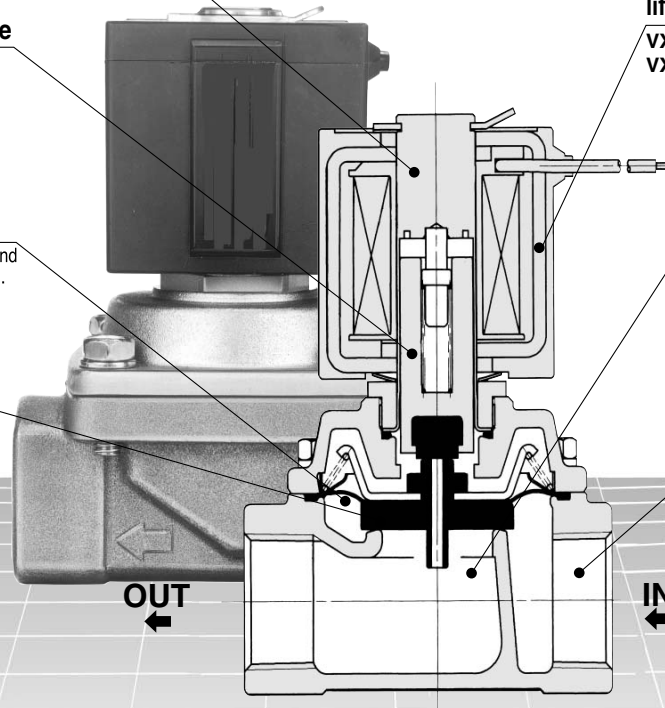

VC □

VDW

VQ

VX2

VX □

VX3

VXA

VN □

LVC

LVA

L VH

LVD

L VQ

LQ

L VN

TI/
TIL

PA

PAX

PB

When power is not supplied

Right after power is supplied (Pilot valve opens)

When power is being supplied (Main valve opens.)

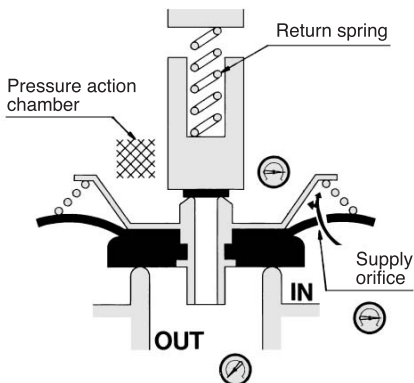

Fluid from the IN side goes through the supply orifice and fills the pressure action chamber. The main valve is kept closed by the force pushing down the valve and the reaction force of the return spring.

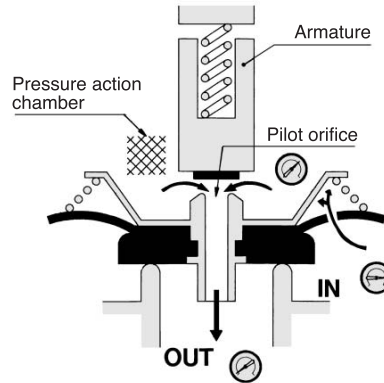

When the power is supplied to the coil, the armature begins to be pulled, and the pilot orifice opens accordingly. The fluid filled in the pressure action chamber flows through the pilot orifice to the OUT side.

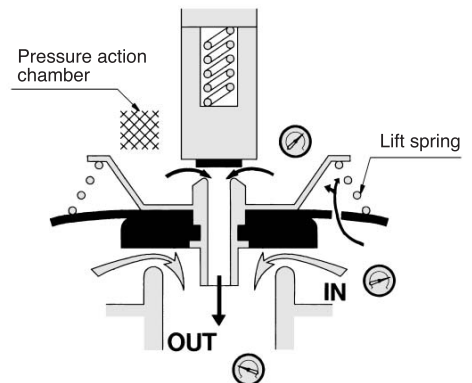

Since the fluid is discharged from the pilot orifice, the pressure in the pressure action chamber decreases. The force pushing down the valve weakens, and the pressure pushing up the valve overcomes the said force. Thus the main valve opens. When the IN side has no pressure, or when the pressure is very low, the reaction force of the lift spring opens the main valve.

How to Order

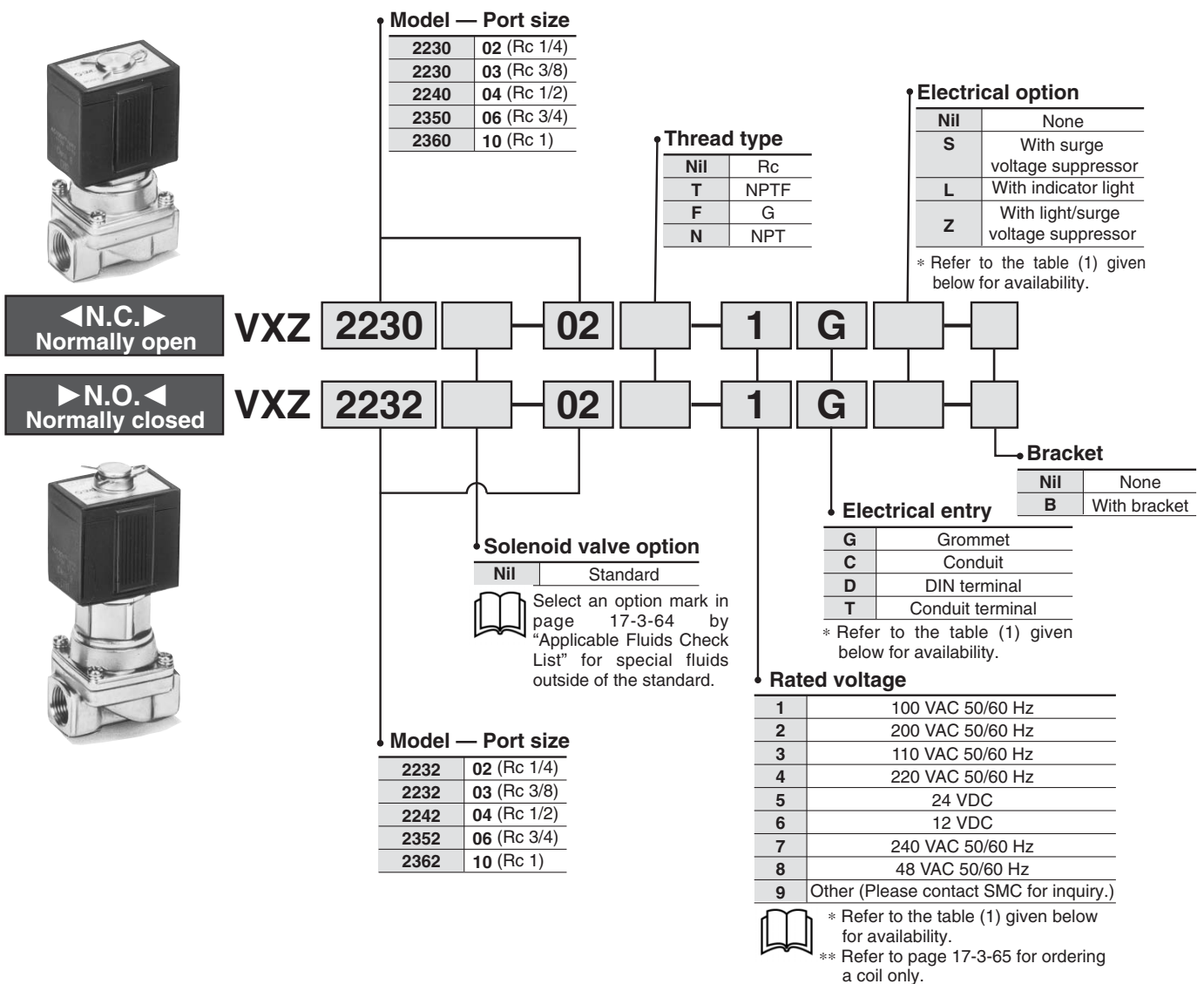

Fluid

Standard specifications	Option ⁽¹⁾	Made to Order ⁽²⁾
Water (standard)	High temperature water (D, E)	Air X500B
Turbine oil		Vacuum (up to 1.3 x 10 ² Pa) ... X500B For pure water X500

Note 1) Refer to page 17-3-64 "Applicable Fluids Check List" for details of special fluids outside of the standard options and specifications.
Note 2) Please contact SMC for details.

Operating Fluid and Ambient Temperature

Temperature conditions	Power source	Operating fluid temperature (°C)					Ambient temperature (°C)
		Water (Standard)	Air (Standard)	Oil (Standard)	High ⁽³⁾ temperature water (D,E,N,P)	High ⁽³⁾ temperature oil (D,N)	
Maximum	AC	60	80	60	99	100	60
	DC	40	60	40	—	—	40
Minimum	AC/DC	1	-10 ⁽¹⁾	-5 ⁽²⁾	—	—	-10

Note 1) Dew point is below -10°C
Note 2) Below 50 cSt
Note 3) "D", "E", "N", "P", etc. in parentheses represents option symbol.

Caution

Be sure to read before handling. Refer to pages 17-6-3 to 17-6-10 for Safety Instructions and Solenoid Valve Precautions.

Table (1)

Rated Voltage-Electrical Entry-Electrical Option

Insulation type	Class B			Class H		
	G	C	D, T	G, C	T	T
Electrical entry	G	C	D, T	G, C	T	T
Electrical option	S ^(Note)	—	S, L, Z	—	S, L, Z	—
AC	1 (100 V)	●	●	●	●	●
	2 (200 V)	●	●	●	●	●
	3 (110 V)	●	●	●	●	●
	4 (220 V)	●	●	●	●	●
DC	7 (240 V)	●	●	—	—	—
	8 (48 V)	●	●	—	—	—
	5 (24 V)	●	●	—	—	—
	6 (12 V)	●	●	—	—	—

Note) Surge voltage suppressor is attached in the middle of lead wire.

Made to Order Specifications

Splashproof Spec. (Based on JIS C 0920)
(Based on IEC529IP-X4)

VXZ Model — Port size — Electrical entry - X36

DIN terminal or class H coil not available.

Pilot Operated 2 Port Solenoid Valve For Zero Pressure Differential Operation Series VXZ22/23

The VX* series will be revised shortly.

◀N.C.▶ Normally closed

Model/Valve Specifications

Port size	Orifice size (mmø)	Model	Min. operating pressure differential (MPa)	Max. operating pressure differential (MPa)						Flow characteristics					Max. system pressure (MPa)	Weight (g)
				Water		Air		Oil		Water, Oil, Steam			Air			
				AC	DC	AC	DC	AC	DC	Av x 10 ⁻⁶ m ²	Cv converted	C[dm ³ /(s·bar)]	b	Cv		
1/4	10	VXZ2230-02	0	1.0	0.7	1.0	0.7	0.7	0.7	46	1.9	8.5	0.44	2.4	1.5	550
3/8	10	VXZ2230-03		1.0	0.7	1.0	0.7	0.7	0.7	58	2.4	11	0.42	2.8		550
1/2	15	VXZ2240-04		1.0	0.7	1.0	0.7	0.7	0.7	130	5.3	23	0.34	6.0		760
3/4	20	VXZ2350-06		1.0	0.7	1.0	0.7	0.7	0.7	220	9.2	38	0.20	9.5		1300

Port size	Orifice size (mmø)	Model	Min. operating pressure differential (MPa)	Max. operating pressure differential (MPa)						Flow characteristics			Max. system pressure (MPa)	Weight (g)
				Water		Air		Oil		Water, Oil, Steam		Air		
				AC	DC	AC	DC	AC	DC	Av x 10 ⁻⁶ m ²	Cv converted	Effective area		
1	25	VXZ2360-10	0	1.0	0.7	1.0	0.7	0.7	0.7	290	12	215	1.5	1480



Note) Values for the grommet type. Add 10 g for the conduit type, 30 g for the DIN terminal type, and 60 g for the conduit terminal type.

- Refer to "Glossary" on page 17-3-15 for details of max. operating pressure differential and max. system pressure.



JIS Symbol

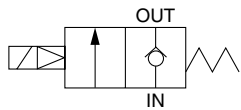

Solenoid Specifications

Model	Power source	Frequency (Hz)	Apparent power (VA)		Power consumption (W) (Holding)	Temperature rise (°C) (Rated voltage)
			Inrush	Holding		
VXZ22	AC	50	60(53)	18	7.5	60
		60	51(44)	12	6	50
VXZ23	AC	50	80	21	11	65
		60	67	17	9.5	60
	DC	—	—	—	11.5	65



- Note) • The return voltage is 20% or more of the rated voltage for AC and 2% or more for DC.
 • The allowable voltage fluctuation rate is ±10% of the rated voltage value for both AC and DC.
 • When the ambient temperature is 20°C ±5°C and rated voltage is applied.
 • Changing coils from AC to DC and vice versa is impossible, because of different core shapes.
 • The apparent power in parentheses is for VXZ2230.

▶N.O.◀ Normally open

Model/Valve Specifications

Port size	Orifice size (mmø)	Model	Min. operating pressure differential (MPa)	Max. operating pressure differential (MPa)						Flow characteristics					Max. system pressure (MPa)	Weight (g)
				Water		Air		Oil		Water, Oil, Steam			Air			
				AC	DC	AC	DC	AC	DC	Av x 10 ⁻⁶ m ²	Cv converted	C[dm ³ /(s·bar)]	b	Cv		
1/4	10	VXZ2232-02	0	0.7	0.6	0.7	0.6	0.7	0.6	46	1.9	8.5	0.44	2.4	1.5	600
3/8	10	VXZ2232-03		0.7	0.6	0.7	0.6	0.7	0.6	58	2.4	11	0.42	2.8		600
1/2	15	VXZ2242-04		0.7	0.6	0.7	0.6	0.7	0.6	130	5.3	23	0.34	6.0		850
3/4	20	VXZ2352-06		0.7	0.6	0.7	0.6	0.7	0.6	220	9.2	38	0.20	9.5		1370

Port size	Orifice size (mmø)	Model	Min. operating pressure differential (MPa)	Max. operating pressure differential (MPa)						Flow characteristics			Max. system pressure (MPa)	Weight (g)
				Water		Air		Oil		Water, Oil, Steam		Air		
				AC	DC	AC	DC	AC	DC	Av x 10 ⁻⁶ m ²	Cv converted	Effective area		
1	25	VXZ2362-10	0	0.7	0.6	0.7	0.6	0.7	0.6	290	12	215	1.5	1550



Note) Values for the grommet type. Add 10 g for the conduit type, 30 g for the DIN terminal type, and 60 g for the conduit terminal type.

- Refer to "Glossary" on page 17-3-15 for details of max. operating pressure differential and max. system pressure.



JIS Symbol

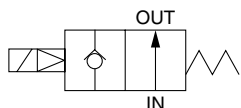

Solenoid Specifications

Model	Power source	Frequency (Hz)	Apparent power (VA)		Power consumption (W) (Holding)	Temperature rise (°C) (Rated voltage)
			Inrush	Holding		
VXZ22	AC	50	66(60)	20	8	55
		60	57(51)	15	6.5	45
VXZ23	AC	50	93	25	11	60
		60	79	20	9.5	50
	DC	—	—	—	11.5	55



- Note) • The return voltage is 20% or more of the rated voltage for AC and 5% or more for DC.
 • The allowable voltage fluctuation rate is ±10% of the rated voltage value for both AC and DC.
 • When the ambient temperature is 20°C ±5°C and rated voltage is applied.
 • Changing coils from AC to DC and vice versa is impossible, because of different core shapes.
 • The apparent power in parentheses is for VXZ2232.

VC □

VDW

VQ

VX2

VX □

VX3

VXA

VN □

LVC

LVA

LVH

LVD

LVQ

LQ

LVN

TI/
TIL

PA

PAX

PB

Applicable Fluids Check List

◀N.C.▶ Normally closed

Refer to pages 17-3-62 and -63 for models and specifications.

Option Symbol and Composition

Option symbol	Seal material	Coil insulation type	Main body, shading coil material
Standard	NBR	B	Brass or BC6, Copper
A	FKM		
B	EPDM		
D	FKM		
E	EPDM	H	Stainless steel, Silver
F <small>Note 1)</small>	FKM		
G	NBR		
H	FKM		
J	EPDM	H	Brass or BC6, Copper
L <small>Note 1)</small>	FKM		
N	FKM		
P	EPDM		
T <small>Note 1)</small> <small>Note 2)</small>	NBR	B	Brass or BC6, Copper
X <small>Note 1)</small> <small>Note 2)</small>	FKM		

 Note 1) Non-lube type. For other options, "-X12" at the end of product number represents the non-lube option.
Note 2) Long service life iron core, but water is not applicable.

▶N.O.◀ Normally open

Refer to pages 17-3-62 and -63 for models and specifications.

Option Symbol and Composition

Option symbol	Seal material	Coil insulation type	Main body, shading coil material	Holder material (in core ass'y)
Standard	NBR	B	Brass or BC6, Copper	Polyacetal
A	FKM			
B	EPDM			
D	FKM			
E	EPDM	H	Stainless steel, Silver	Stainless steel
F <small>Note 1)</small>	FKM			
G	NBR			
H	FKM			
J	EPDM	H	Brass or BC6, Copper	Polyacetal
L <small>Note 1)</small>	FKM			
N	FKM			
P	EPDM			
T <small>Note 1)</small> <small>Note 2)</small>	NBR	B	Brass or BC6, Copper	Polyacetal
X <small>Note 1)</small> <small>Note 2)</small>	FKM	H	Brass or BC6, Copper	Stainless steel

 Note 1) Non-lube type. For other options, "-X12" at the end of product number represents the non-lube option.
Note 2) Long service life iron core, but water is not applicable.

Fluid Name and Option

Fluid (Application)	Option symbol and body material	
	Brass or BC6	Stainless steel
Ethyl alcohol	F, B	L, J
Ethylene glycol	B	J
Caustic soda (25% ≥)	—	J
Gas oil	A	H
Silicon oil	A	H
Fuel oil (up to 60°C)	A	H
Fuel oil (up to 100°C)	D	N
Steam system (Boiler water)	—	G, J
Steam system (Condensate)	E	P
Insulation oil	A	H
Naphtha	A	H
Parachloroethylene	A	H
Brake oil	B	J
Water (up to 99°C)	D, E	N, P

 Note) If using for other fluids, please contact SMC.

Fluid Name and Option

Fluid (Application)	Option symbol and body material	
	Brass or BC6	Stainless steel
Caustic soda (25% ≥)	—	J
Gas oil	A	H
Silicon oil	A	H
Fuel oil (up to 60°C)	A	H
Fuel oil (up to 100°C)	D	N
Steam system (Boiler water)	—	G, J
Steam system (Condensate)	E	P
Insulation oil	A	H
Parachloroethylene	A	H
Brake oil	B	J
Water (up to 99°C)	E	N, P

Selection Procedure

- Selection of port size
- Selection of material according to the operating temperature and type of fluid
- Selection of power voltage and electrical entry

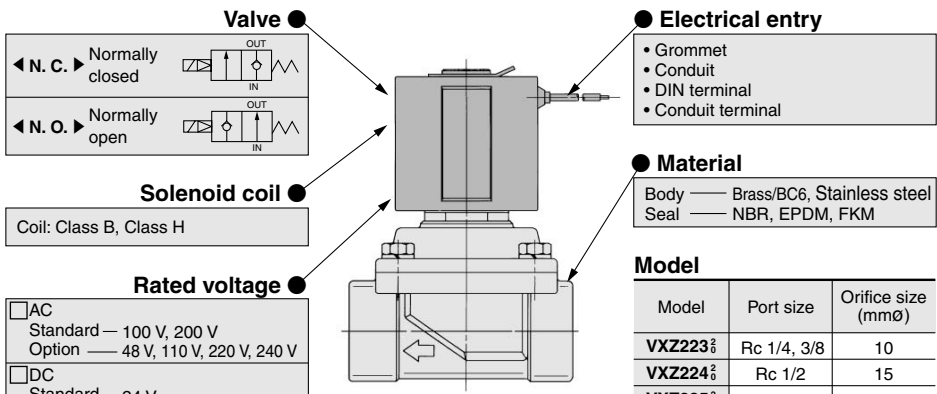

Model

Model	Port size	Orifice size (mmØ)
VXZ223 ²	Rc 1/4, 3/8	10
VXZ224 ²	Rc 1/2	15
VXZ235 ²	Rc 3/4	20
VXZ236 ²	Rc 1	25

Pilot Operated 2 Port Solenoid Valve For Zero Pressure Differential Operation **Series VXZ22/23**

The VX* series will be revised shortly.

Construction

◀N.C.▶ Normally closed

▶N.O.◀ Normally open

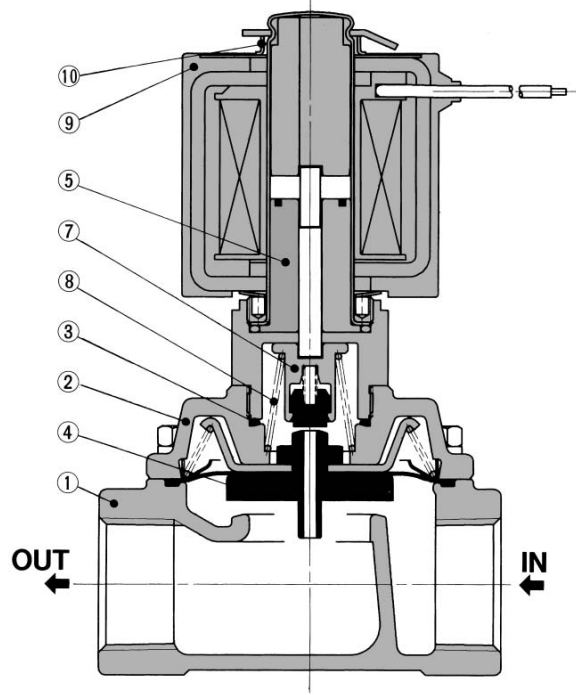
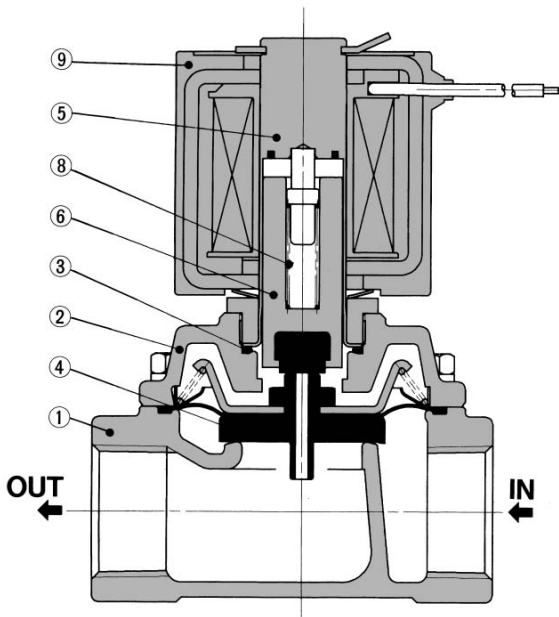

Component Parts

No.	Description	Material	
		Standard	Option
①	Body	Brass/BC6	Stainless steel
②	Bonnet	Brass	Stainless steel
③	O-ring	NBR	FKM/EPDM
④	Diaphragm assembly	Stainless steel, NBR	Stainless steel FKM/Stainless steel, EPDM
⑤	Core assembly	Stainless steel, Copper	Stainless steel, Silver

No.	Description	Material	
		Standard	Option
⑥	Armature assembly	Stainless steel NBR	Stainless steel FKM/Stainless steel, EPDM
⑦	Holder assembly	POM, NBR	Stainless steel FKM/Stainless steel, EPDM
⑧	Return spring	Stainless steel	—
⑨	Coil assembly	Class B, molded	Class H, molded
⑩	Color	Stainless steel	—

Coil Assembly Part No.

VX021 — **002** **CBTZ** — **01**

Solenoid no. ↓

No.	Applicable valve model
002	VXZ22 □□
003	VXZ23 □□

Coil combination code
(Refer to the table below.)

Rated voltage

01	100 VAC 50/60 Hz	08	48 VAC 50/60 Hz
02	200 VAC 50/60 Hz	13	24 VAC 50/60 Hz
03	110 VAC 50/60 Hz	23	440 VAC 50/60 Hz
04	220 VAC 50/60 Hz	51	6 VDC
05	24 VDC	53	48 VDC
06	12 VDC	55	100 VDC
07	240 VAC 50/60 Hz	56	110 VDC

Note) The voltage codes of 01 to 08 when the suffix "0" is removed, are the same as the solenoid valve model codes.

Applicable Voltage for Electrical Option

Power source	Voltage code	Surge voltage suppressor	Indicator light
AC	01	●	●
	02	●	●
	03	●	●
	04	●	●
	07	●	—
	08	●	—
DC	05	●	●
	06	●	—

Coil Combination

Grommet

Symbol	Insulation	Option
GB	Class B	—
GBS		With surge voltage suppressor
GH	Class H	—

Conduit

Symbol	Insulation	Option
CB	Class B	—
CBT		Terminal
CBTS		With terminal, surge voltage suppressor
CBTL		With terminal, indicator light
CBTZ		With terminal, light/ surge voltage suppressor
CH	Class H	—
CHT		Terminal
CHTS		With terminal, surge voltage suppressor
CHTL		With terminal, indicator light
CHTZ		With terminal, light/ surge voltage suppressor

DIN Terminal

Symbol	Insulation	Option
DB	Class B	—
DBT		With connector
DBTS		With connector, surge voltage suppressor
DBTL		With connector/indicator light
DBTZ		With connector, light/ surge voltage suppressor
		—

Dimensions

Grommet: G

◀N.C.▶ Normally closed: VXZ2230/2240/2350/2360

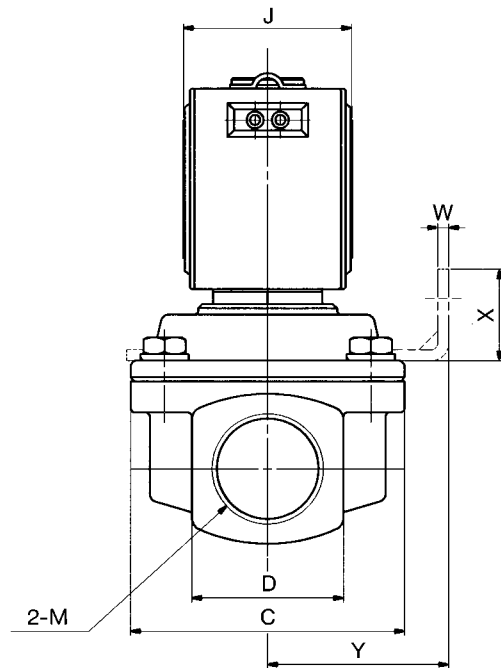
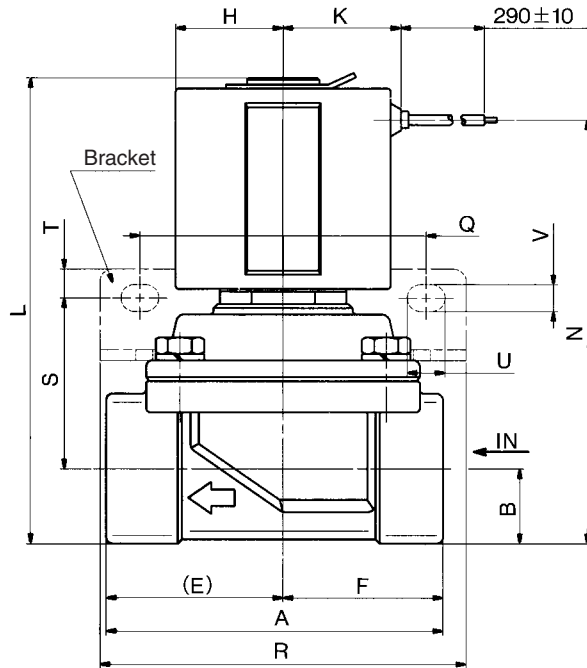

▶N.O.◀ Normally open: VXZ2232/2242/2352/2362

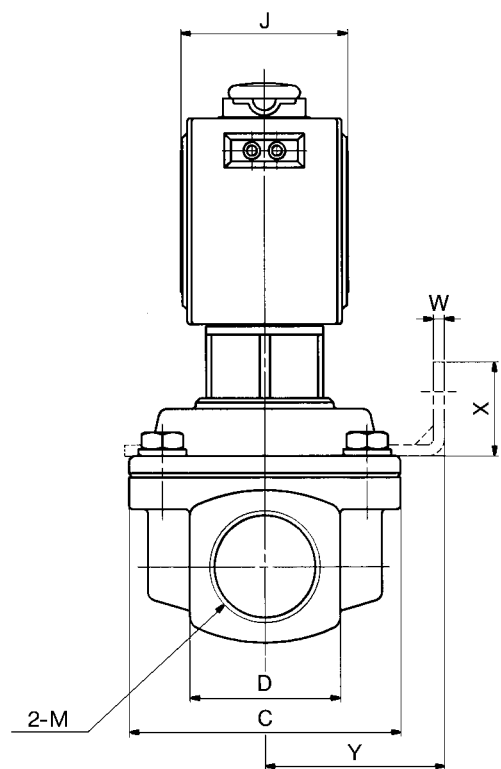
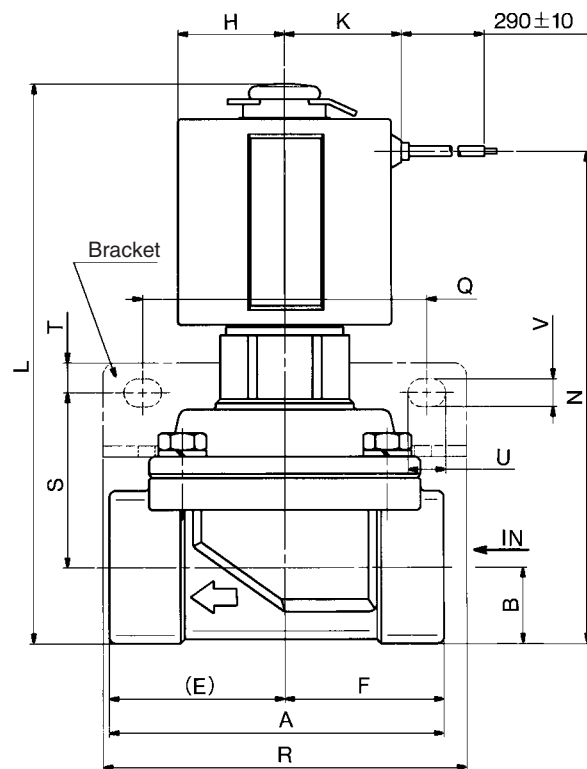

Model		Port size Rc M	N.C.										N.O.											
N.C.	N.O.		A	B	C	D	E	F	H	J	K	L	N	L	N	Q	R	S	T	U	V	W	X	Y
VXZ2230	VXZ2232	1/4, 3/8	50	11	40	22	24	26	23	35	25	89	79.5	108	93	52	67	25.5	6	7.5	5.5	1.6	14	28
VXZ2240	VXZ2242	1/2	63	14	52	28	33	30	23	35	25	97	87.5	117	102	60	75	33	7	8.5	6.5	2.3	17	35
VXZ2350	VXZ2352	3/4	80	18	65	36	42	38	25.5	40	28	112	101.5	130	115.5	68	87	41	7	9	6.5	2.6	22	43
VXZ2360	VXZ2362	1	90	21	70	42	47	43	25.5	40	28	117	106.5	135	120.5	73	92	44	7	9	6.5	2.6	22	45

Pilot Operated 2 Port Solenoid Valve Series VXZ22/23

For Zero Pressure Differential Operation

The VX* series will be revised shortly.

Conduit: C

◀N.C.▶ Normally closed

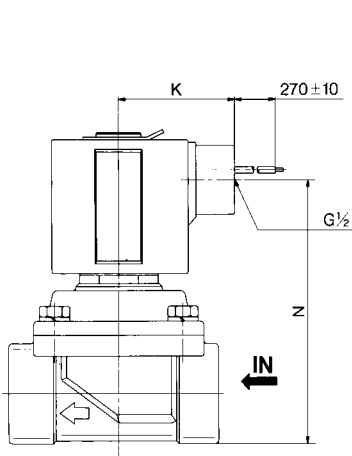

▶N.O.◀ Normally open

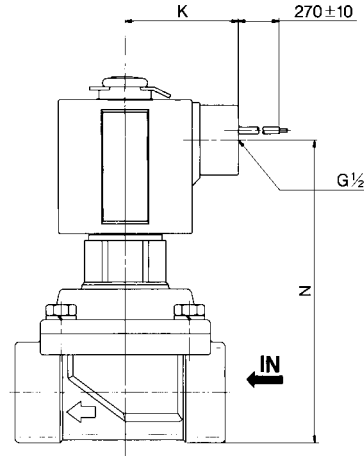

Model		K	N	
N.C.	N.O.		N.C.	N.O.
VXZ2230	VXZ2232	41	72	88
VXZ2240	VXZ2242	41	80	97
VXZ2350	VXZ2352	44	95	108.5
VXZ2360	VXZ2362	44	100	113.5

DIN terminal: D

◀N.C.▶ Normally closed

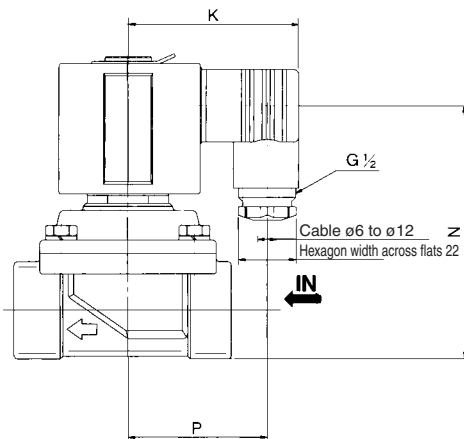

▶N.O.◀ Normally open

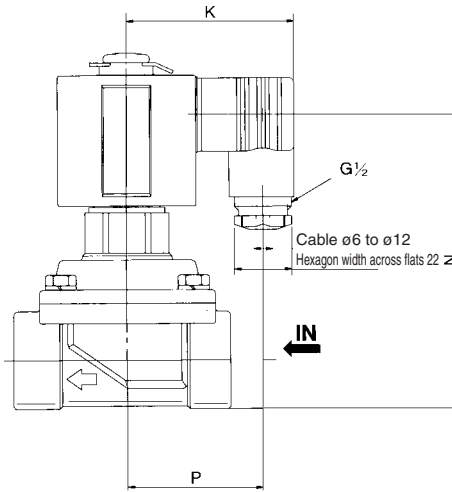

Model		K	N		P
N.C.	N.O.		N.C.	N.O.	
VXZ2230	VXZ2232	60	72	88	48
VXZ2240	VXZ2242	60	80	97	48
VXZ2350	VXZ2352	62	95	108.5	50
VXZ2360	VXZ2362	62	100	113.5	50

Conduit terminal: T

◀N.C.▶ Normally closed

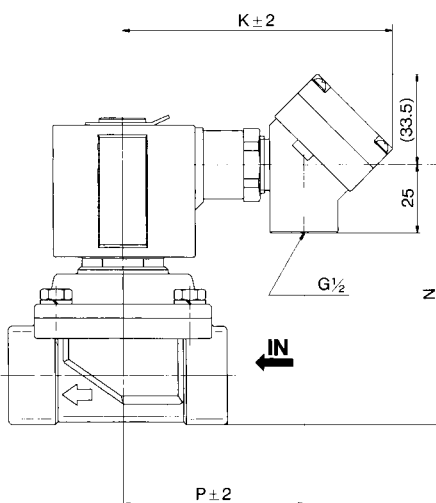

▶N.O.◀ Normally open

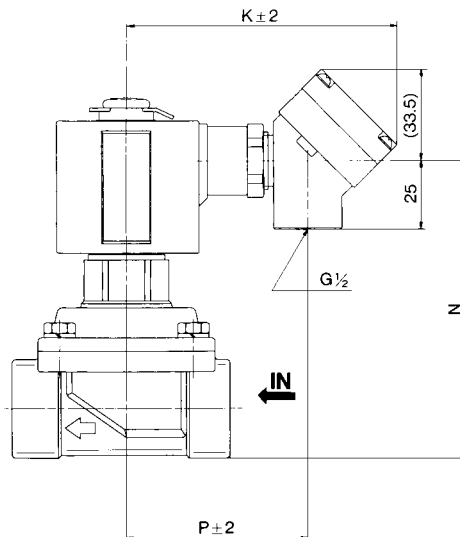

Model		K	N		P
N.C.	N.O.		N.C.	N.O.	
VXZ2230	VXZ2232	95	72	88	62
VXZ2240	VXZ2242	95	80	97	62
VXZ2350	VXZ2352	97	95	108.5	64
VXZ2360	VXZ2362	97	100	113.5	64

VC□

VDW

VQ

VX2

VX□

VX3

VXA

VN□

LVC

LVA

LVH

LVD

LVQ

LQ

LVN

TI/
TIL

PA

PAX

PB

Construction

◀N.C.▶
Normally closed

Common parts

▶N.O.◀
Normally open

