



ISO Cylinder

Series C85



ø8, ø10, ø12, ø16, ø20, ø25

Conforming to ISO 6432 and CETOP RP52P.



- CJ1
- CJP
- CJ2
- CM2
- CG1
- MB
- MB1
- CA2
- CS1
- C76
- C85**
- C95
- CP95
- NCM
- NCA
- D-
- X
- 20-
- Data

Series Variations

Series	Action	Rod	Cushion	Head cover style				Switch mount		Rod boot (ø20, 25)	Bore size (mm)	Page
				N	E	F	Y	Rail	Band			
Standard Series C85 	Double acting	Single	Rubber	●	●	●	●	●	●	●	8 to 25	6-11-6
			Air	●	●	●	●	●	●	●	10 to 25	
	Double	Rubber	●	●	●	●	●	●	●	●	8 to 25	
		Air	●	●	●	●	●	●	●	●	10 to 25	
Single acting	Single (SR, SE)	Rubber	●	●	●	●	●	●	●	8 to 25	6-11-23	
Non-rotating rod Series C85K 	Double acting	Single	Rubber	●	●	●	●	●	●	8 to 25	6-11-6	
	Single acting	Single (SR, SE)	Rubber	●	●	●	●	●	●	8 to 25	6-11-23	
	(Not for SE)											
Direct mount Series C85R 	Base	Double acting	Single	Rubber	●	●	●	●	●	8 to 25	6-11-38	
	Front	Double acting	Single	Rubber	●	●	●	●	●	20, 25		

SR = Spring Return
SE = Spring Extended

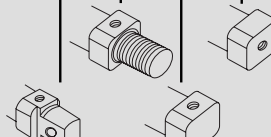

Series C85: ø8, ø10, ø12,

ø16, ø20, ø25,

Extended Service Life
Automated assembly guarantees 100% repeatable mounting accuracy. With abrasion resistant seals and replaceable nose seal, C85 cylinders offer exceptional service life.

Corrosion Resistance
All parts are corrosion resistant. End covers and clevis are specially anodised while barrel is stainless steel. Piston rod is stainless steel up to ø16. ø20 to ø40 is C45 hard chromed.

ISO Standard 6432
is compliant with auto switch type.

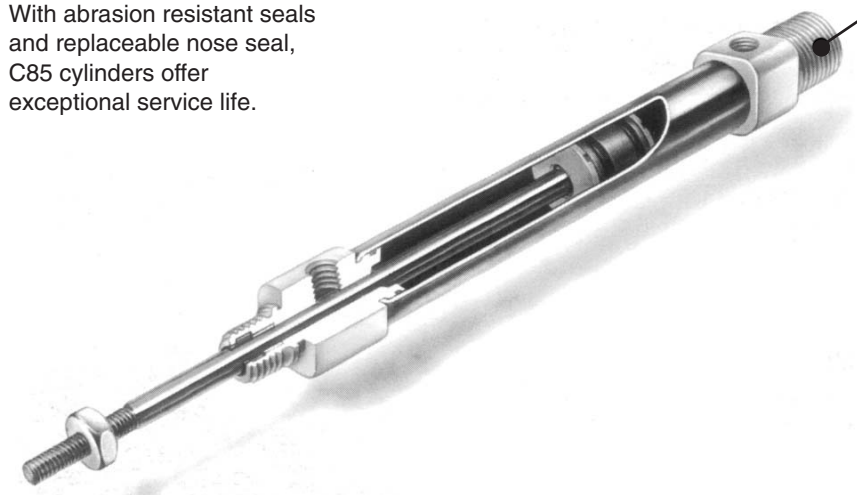

C85: ø8, ø10, ø12, ø16

Bronze Bush Bearing
High quality bronze bush in clevis bearing extends the life of cylinder.

High Dust Resistance
A unique rod seal is employed to prevent entry of dust. The effectiveness of the seal makes the cylinder suitable for use in extremely dusty environments.

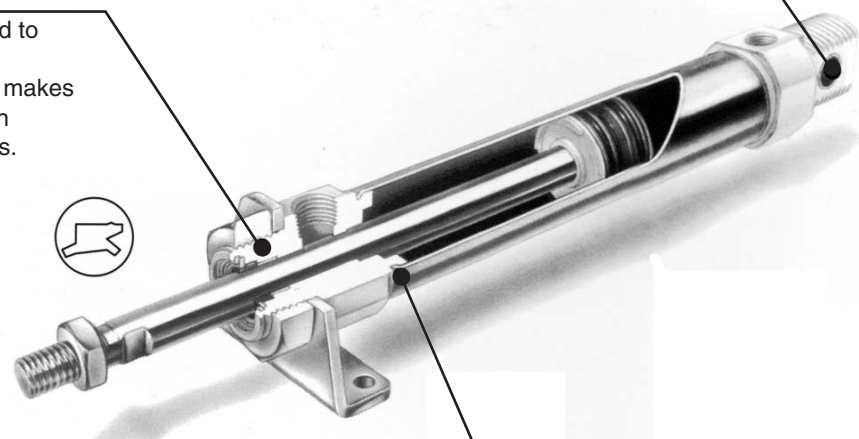

C85: ø20, ø25

Leak Proof Assembly
Double swaging of the end covers of the barrel provides an absolutely air tight union.

Easy-accurate Mounting
Simple space-saving design with high dimensional accuracy makes these cylinders very easy to use. Large spanner flats on the rod and head covers greatly simplify their installation and positioning.

High Speed Actuation
Low friction and the standard elastomer cushion seals allow piston speeds up to 1500 mm/s. Either rubber bumper or air cushions are available.

Replaceable Rod Seal
Rod seal can be quickly replaced, greatly extending the cylinder life. (C85 ø20, 25).

Minimized Side Clearance
The close tolerance of the piston rod in the front end bush allows greater side loading.

Strong, Corrosion-proof Barrel
The risk of breakage or deformation due to external impacts is reduced by the use of harder, heavy walled stainless steel tube.

C85: ø20, ø25

Mounting Flexibility
Different head covers allow a great variety of mounting options.

Series Variations

Series	Action	Variations	Basic integrated clevis (N)						Rod boot (Only ø20, ø25)		Only bores ø20, ø25 mm				Bore ø8 to ø16 and all non-rotating piston rod are already stainless steel			
			Bore size (mm)						Double end (E)		Auto switch		-XB6	-XB7	-XB9	-XC4	R	R2
			8	10	12	16	20	25	Front nose	Front nose in line port (Y)	Rail mounting	Band mounting	High temp.	Low temp.	Low speed	Heavy duty scraper		
C85	Double acting, Single rod	Rubber cushion	•	•	•	•	•	•	•	•	•	•	•	•	•	•	•	•
		Air cushion	•	•	•	•	•	•	•	•	•	•	•	•	•	•	•	•
		Non rotating	•	•	•	•	•	•	•	•	•	•	•	•	•	•	•	•
		Direct mount Bottom side mounting	•	•	•	•	•	•	•	•	•	•	•	•	•	•	•	•
		Direct mount Front side mounting	•	•	•	•	•	•	•	•	•	•	•	•	•	•	•	•
	Double acting, Double rod	Rubber cushion	•	•	•	•	•	•	•	•	•	•	•	•	•	•	•	•
		Air cushion	•	•	•	•	•	•	•	•	•	•	•	•	•	•	•	•
	Single acting, Spring return	Rubber cushion	•	•	•	•	•	•	•	•	•	•	•	•	•	•	•	•
		Non rotating	•	•	•	•	•	•	•	•	•	•	•	•	•	•	•	•
	Single acting, Spring extended	Rubber cushion	•	•	•	•	•	•	•	•	•	•	•	•	•	•	•	•
Non rotating		•	•	•	•	•	•	•	•	•	•	•	•	•	•	•	•	

- CJ1
- CJP
- CJ2
- CM2
- CG1
- MB
- MB1
- CA2
- CS1
- C76
- C85
- C95
- CP95
- NCM
- NCA
- D-
- X
- 20-
- Data



Stroke Selection

The relation between the cylinder size and the maximum stroke depending on the mounting style

Assuming that the force that is generated by the cylinder itself acts as a buckling force on the piston rod or on the piston rod and the cylinder tube, the table below indicates in centimeters the maximum stroke that can be used, which was obtained through calculation. Therefore, it is possible to find the maximum stroke that can be used with each cylinder size according to the relationship between the level of the operating pressure and the type of cylinder mounting, regardless of the load factor.



Reference: Even under a light load, if the piston rod has been stopped by an external stopper at the extending side of the cylinder, the maximum force generated by the cylinder will act upon the cylinder itself.

The maximum stroke at which the cylinder can be operated under a lateral load

The region that does not exceed the bold solid line represents the allowable lateral load in relation to the cylinder of a given stroke length. In the graph, the range of the broken line shows that the long stroke limit has been exceeded. In this region, as a rule, operate the cylinder by providing a guide along the direction of movement.

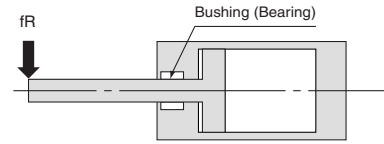

(cm)

Mounting style			Nominal symbol	Operating pressure (MPa)	Maximum stroke that can be used according to buckling strength					
Mounting bracket diagram					C85					
Foot: L	Rod side flange: F	Head side flange: G		8	10	12	16	20	25	
			L T	0.3	24	18	36	26	38	48
				0.5	18	14	27	19	29	36
				0.7	14	11	22	16	23	30
			G	0.3	9	6	15	10	15	20
				0.5	6	4	10	6	10	14
				0.7	4	3	8	4	8	11
Clevis: C, D	Rod side trunnion: U		C D	0.3	22	17	35	24	36	46
				0.5	16	12	26	18	27	34
				0.7	13	10	21	14	22	28
			U	0.3	(40)*	(40)*	(40)*	(40)*	80	(100)*
				0.5	38	30	(40)*	(40)*	61	77
				0.7	32	25	(40)*	35	51	64
Head side trunnion: U	Center trunnion: O		U	0.3	22	17	35	24	37	47
				0.5	16	12	26	18	27	35
				0.7	13	10	21	14	22	28
			T	0.3	(40)*	(40)*	(40)*	(40)*	(100)*	(100)*
				0.5	(40)*	(40)*	(40)*	(40)*	89	(100)*
				0.7	(40)*	36	(40)*	(40)*	74	93
Foot: L	Rod side flange: F	Head side flange: G	L T	0.3	33	26	(40)*	37	54	69
				0.5	25	19	39	27	41	52
				0.7	20	15	32	22	33	43
			G	0.3	(40)*	38	(40)*	(40)*	79	(100)*
				0.5	37	29	(40)*	(40)*	60	76
				0.7	30	23	(40)*	34	50	63

Series C85: ø8, ø10, ø12, ø16

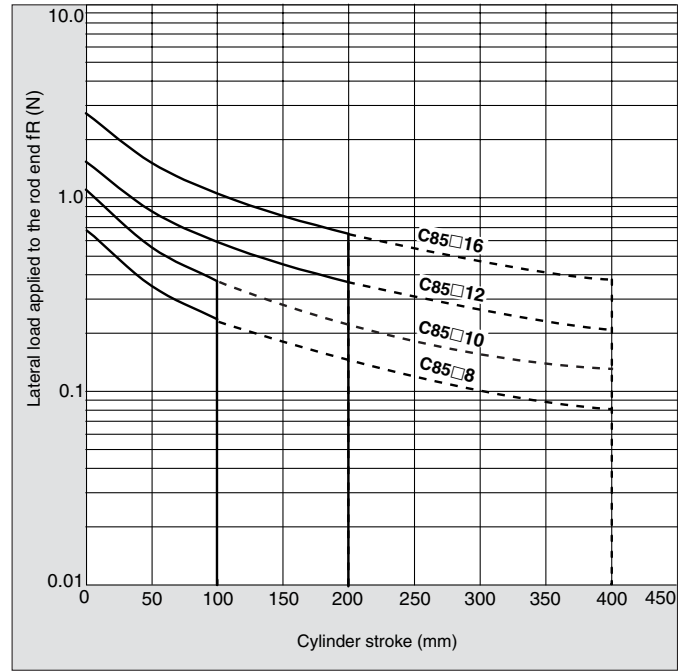

Series C85: ø20, ø25

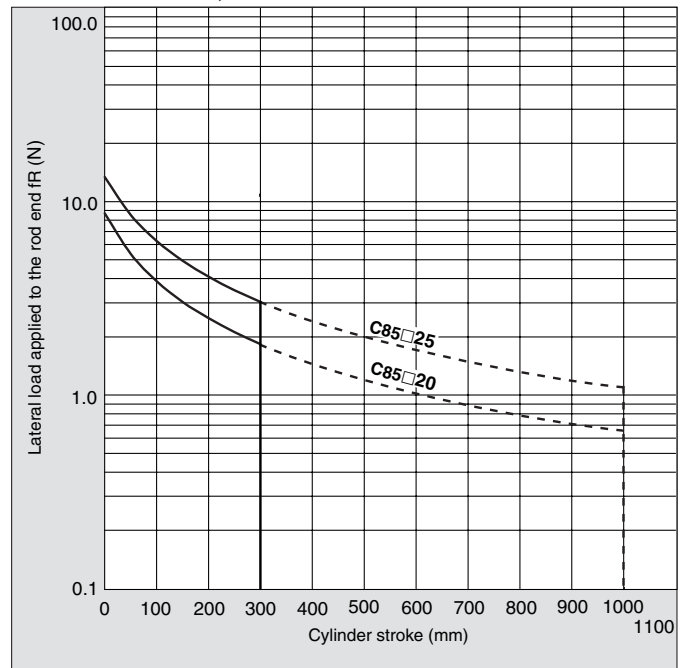

CJ1

CJP

CJ2

CM2

CG1

MB

MB1

CA2

CS1

C76

C85

C95

CP95

NCM

NCA

D-

-X

20-

Data

ISO Cylinder: Standard/Non-rotating Type Double Acting, Single/Double Rod

Series C85

ø8, ø10, ø12, ø16, ø20, ø25

How to Order

Double acting Single rod C D 85

Double acting Double rod C D 85 W

Built-in magnet

Nil	None
D	Built-in magnet

Type

Nil	Standard
K	Non-rotating rod (Rubber cushion only)

Mounting style

Symbol	Mounting
N	Basic integrated clevis
E**	Double end
F**	Front nose
Y**	Front nose in line port

* Double acting, Double rod:
Only double end style (E).
** Except air cushion type.

Stroke

Bore size (mm)	Standard stroke (mm)**	Max. stroke (mm)		
		Standard	Non-rotating	Double rod
8*	10, 25, 40, 50, 80, 100	400	100	100
10			200	200
12	10, 25, 40, 50, 80, 100, 125, 160, 200	1000	1000	500
16				
20	10, 25, 40, 50, 80, 100, 125, 160, 200, 250, 300	1000	1000	500
25				

* Not available with air cushion.
**Other strokes available on request.

Cushion

Nil	Rubber cushion (Standard)
C	Air cushion (Only "N" execution, bores 10 to 25 mm)

Auto switch mounting type

A	Rail mounting
B	Band mounting

Applicable auto switches and bands are shown on page 6-11-44. Please order auto switches and bands separately.

Option

R	Stainless steel piston rod, rod end nut and mounting nut
R2	Stainless steel piston rod and rod end nut

Note) Please refer to page 6-11-47 for additional options. Only one option can be selected.

Mounting Bracket Part No.

Mounting bracket		Bore size (mm)					
		8	10	12	16	20	25
Mounting bracket	Foot (1 pc.)	C85L10A	C85L16A			C85L25A	
	Foot (2 pcs. with mounting nut 1 pc.)	C85L10B	C85L16B			C85L25B	
	Flange	C85F10	C85F16			C85F25	
	Trunnion	C85T10	C85T16			C85T25	
	Clevis	C85C10	C85C16			C85C25	
Accessory	Single knuckle joint	KJ4D	KJ6D	KJ8D	KJ10D		
	Double knuckle joint	GKM4-8	GKM6-10	GKM8-16	GKM10-20		
	Floating joint	JA10-4-070	JA15-6-100	JA20-8-125	JA30-10-125		

Replacement Parts For Standard Cylinders

Bore size (mm)	Part no.	Note
20	C85-20PS	Every set includes: n°1 rod seal
25	C85-25PS	n°1 seal retaining washer n°1 retaining ring

For Non-rotating Cylinders ("K")

Bore size (mm)	Part no.	Note
20	C85K-20PS	Every set includes: n°1 rod seal
25	C85K-25PS	n°1 seal retaining washer n°1 retaining ring

ISO Cylinder: Standard/Non-rotating Type Double Acting, Single/Double Rod **Series C85**

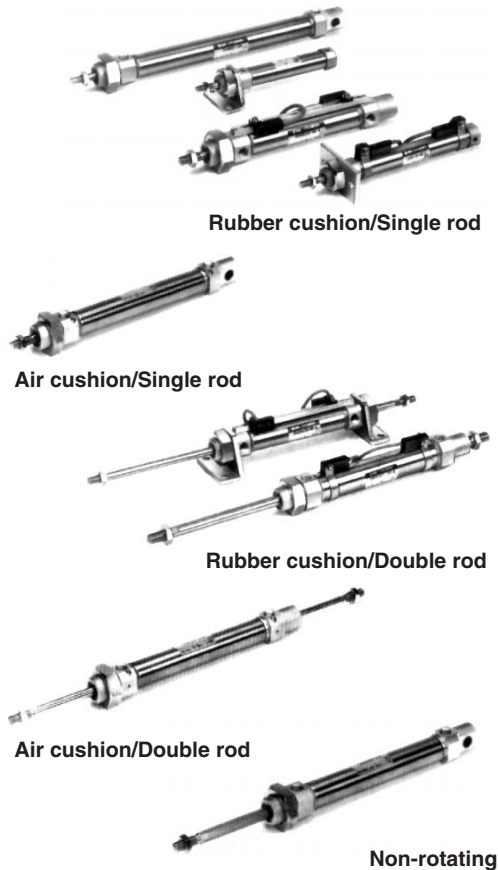

Specifications

Bore size (mm)		8	10	12	16	20	25
Piston rod dia. (mm)		4	4	6	6	8	10
Piston rod thread		M4 x 0.7	M4 x 0.7	M6 x 1	M6 x 1	M8 x 1.25	M10 x 1.25
Port size		M5 x 0.8	M5 x 0.8	M5 x 0.8	M5 x 0.8	G 1/8	G 1/8
Action		Double acting, Single/Double rod					
Fluid		Air					
Proof pressure		1.5 MPa					
Max. operating pressure		1.0 MPa					
Min. operating pressure	Spring return	0.1 MPa	0.08 MPa	0.05 MPa	0.05 MPa		
	Spring extended				0.08 MPa		
Ambient and fluid temperature		-20 to 80°C (Built-in magnet: -10 to 60°C)					
Cushion		Rubber cushion, Air cushion (Except ø8) (Non-rotating: Rubber bumper only)					
Lubrication		Not required. Use turbine oil Class 1 ISO VG32, if lubricated.					
Rod boot	Nylon tarpaulin	—				Max. ambient temperature 60°C	
	Heat resistant tarpaulin	—				Max. ambient temperature 110°C*	
Piston speed		50 to 1500 mm/s					
Allowable kinetic energy	Rubber cushion	0.02 J	0.03 J	0.04 J	0.09 J	0.27 J	0.4 J
	Air cushion	—	0.17 J	0.19 J	0.4 J	0.66 J	0.97 J
Non-rotating accuracy		±1° 30'	±1° 30'	±1°	±1°	±0° 42'	±0° 42'
Stroke tolerance (mm)		0/+1				0/+1.4	

* Maximum ambient temperature of rod boots only.

JIS Symbol

Double acting, Single rod



Rubber cushion

Air cushion

Double acting, Double rod

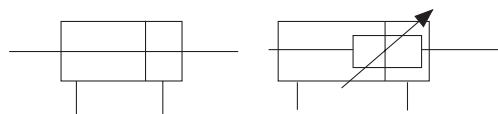

Rubber cushion

Air cushion

Non-rotating rod: Double acting, Single rod

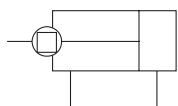

Weight (Standard, Non-rotating rod)

(g)

Bore size (mm)		8	10	12	16	20	25
Double action	Basic weight	45	49	96	109	183(203)	258(286)
	Add'l weight for each 10 mm of stroke	3	3.2	6.2	7.2	11.8	18.4
Mounting bracket	C85L□A	20		40		95	
	C85L□B	55		105		210	
	C85F□	12		25		90	
	C85T□	20		50		75	
	C85C□	20		40		85	
Accessory	Single knuckle joint	KJID		17		25	45 70
	Double knuckle joint	GKM□-□		10		20	50 100
	Floating joint	JA□-□-□		10		20	50 70

Calculation: (Example) C85N10-50, C85F10

Basic weight ————— 49 (ø10)g

Additional weight ——— 3.2/10 mm of stroke

Cylinder stroke ——— 50 mm

Mounting bracket ——— 12g

49 + 3.2 x 50/10 = 65g 65 + 12 = 77g

() : In the case of air cushion

CJ1

CJP

CJ2

CM2

CG1

MB

MB1

CA2

CS1

C76

C85

C95

CP95

NCM

NCA

D-

-X

20-

Data

Series C85

Auto Switch Mounting, Minimum Possible Cylinder Stroke

Band Mounting Style

Bore size: $\phi 8, \phi 10, \phi 12, \phi 16$

(mm)

Auto switch model	No. of auto switches				1 pc.
	3 pcs.		2 pcs.		
	Different sides	Same side	Different sides	Same side	
D-C7□ D-C80	55	90	15	50	10
D-C73C D-C80C D-H7C	65	105	15	65	10
D-H7□ D-H7□W D-H7BAL D-H7NF	60	105	15	60	10

Rail Mounting Style

Bore size: $\phi 8, \phi 10, \phi 12, \phi 16$

(mm)

Auto switch model	No. of auto switches		1 pc.
	3 pcs.	2 pcs.	
	D-A7□/A80 D-A73C/A80C	35	
D-A7□H D-A80H	45	10	5
D-A79W *	40	15	10
D-F7□ D-J79	45	5	5
D-F7□V D-J79C	30	5	5
D-F7□W D-J79W D-F7BAL D-F79F	55	15	10
D-F7□WV D-F7BAVL	40	15	10

* "D-A79W" can not be mounted on bore size $\phi 8, \phi 10, \phi 12$ cylinder.

Band Mounting Style

Bore size: $\phi 20, \phi 25$

(mm)

Auto switch model	No. of auto switches				1 pc.
	2 pcs.		n pcs.		
	Different sides	Same side	Different sides	Same side	
D-C7□ D-C80	15	50	$15 + 45 \binom{n-2}{2}$ (n = 2, 4...)	$50 + 45(n-2)$	10
D-C73C D-C80C D-H7C	15	65	$15 + 45 \binom{n-2}{2}$ (n = 2, 4...)	$65 + 50(n-2)$	10
D-H7□ D-H7□W D-H7BAL D-H7NF	15	60	$15 + 45 \binom{n-2}{2}$ (n = 2, 4...)	$60 + 55(n-2)$	10

Rail Mounting Style

Bore size: $\phi 20, \phi 25$

(mm)

Auto switch model	No. of auto switches		1 pc.
	2 pcs.	n pcs.	
	D-A7□/A80 D-A7□H/A80H D-A73C/A80C D-F7□ D-F7□V D-J79 D-J79C	10	
D-A79W D-F7□W D-J79W D-F7BAL D-F79F D-F7□WV D-F7BAVL	15	$15 + 35 \binom{n-2}{2}$ (n = 2, 4...)	10

ISO Cylinder: Standard/Non-rotating Type Double Acting, Single/Rod Series C85

Construction

[First angle projection]

Double acting, Single rod
C□85□8 to 16 Rubber cushion (Disassembly is not possible.)

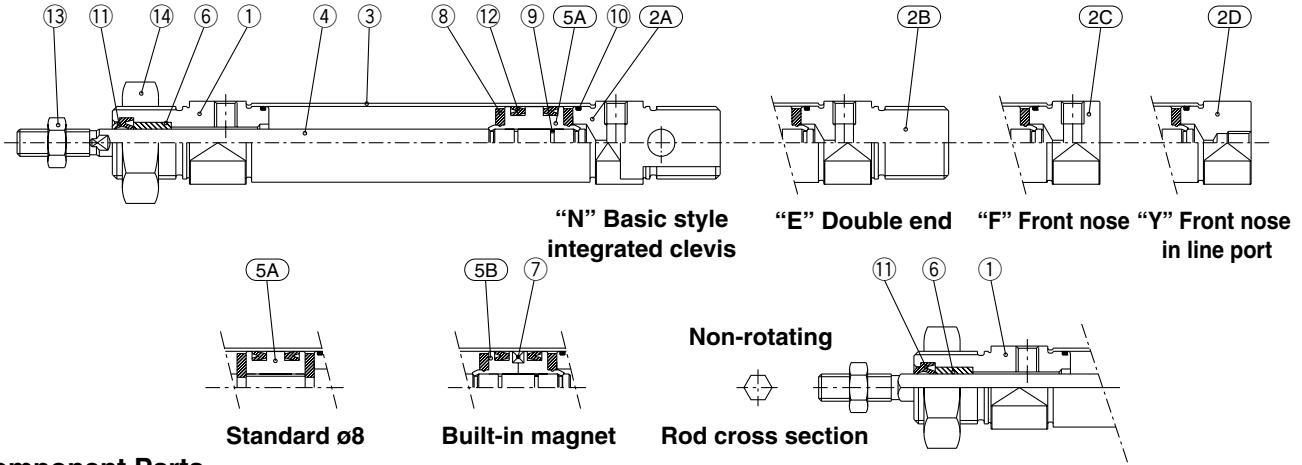

Component Parts

No.	Description	Material	Qty.	Note
①	Rod cover	Aluminum alloy	1	White anodized
②A	Head cover N	Aluminum alloy	1	White anodized
②B	Head cover E	Aluminum alloy	1	White anodized
②C	Head cover F	Aluminum alloy	1	White anodized
②D	Head cover Y	Aluminum alloy	1	White anodized
③	Cylinder tube	Stainless steel	1	
④	Piston rod	Stainless steel	1	
⑤A	Piston A	Brass	1	
⑤B	Piston B	Brass	2	(Switch type piston)

No.	Description	Material	Qty.	Note
⑥	Bush	Sintered bronze	1	
⑦	Magnet	Magnet	1	(Switch type only)
⑧	Bumper	Urethane	2	
⑨	Piston gasket	NBR	1	(2 for switch type)
⑩	Tube gasket	NBR	2	
⑪	Rod seal	NBR	1	
⑫	Piston seal	NBR	2	
⑬	Rod end nut	Carbon steel	1	Nickel plating
⑭	Mounting nut	Carbon steel	1	Nickel plating

C□85□20/25 Rubber cushion

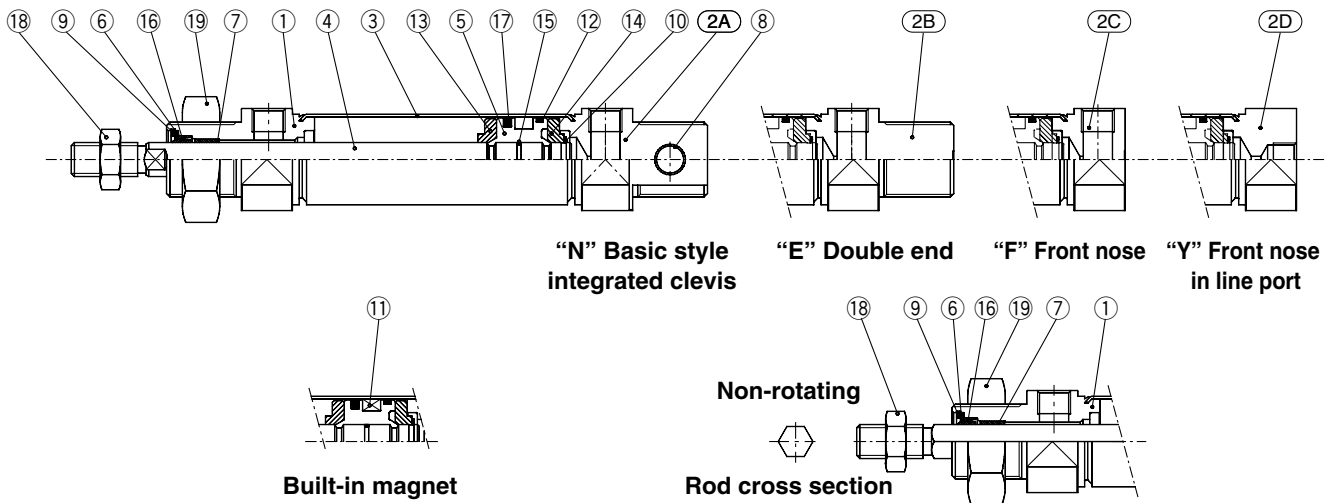

Component Parts

No.	Description	Material	Qty.	Note
①	Rod cover	Aluminum alloy	1	White anodized
②A	Head cover N	Aluminum alloy	1	White anodized
②B	Head cover E	Aluminum alloy	1	White anodized
②C	Head cover F	Aluminum alloy	1	White anodized
②D	Head cover Y	Aluminum alloy	1	White anodized
③	Cylinder tube	Stainless steel	1	
④	Piston rod	Carbon steel	1	Hard chrome plated
⑤	Piston	Aluminum alloy	1	Chromate
⑥	Plain washer	Stainless steel	1	
⑦	Bush	Sintered bronze	1	
⑧	Bush	Sintered bronze	2	

No.	Description	Material	Qty.	Note
⑨	Retaining ring	Carbon steel	1	Nickel plating
⑩	Retaining ring	Stainless steel	1	
⑪	Magnet	Magnet	1	(Switch type only)
⑫	Wear ring	Resin	1	
⑬	Bumper A	Urethane	1	
⑭	Bumper B	Urethane	1	
⑮	Piston gasket	NBR	1	
⑯	Rod seal	NBR	1	
⑰	Piston seal	NBR	1	
⑱	Rod end nut	Carbon steel	1	Nickel plating
⑲	Mounting nut	Carbon steel	1	Nickel plating

CJ1

CJP

CJ2

CM2

CG1

MB

MB1

CA2

CS1

C76

C85

C95

CP95

NCM

NCA

D-

-X

20-

Data

Series C85

Construction

[First angle projection]

Double acting, Single rod

C□85□10 to 16 Air cushion (Disassembly is not possible.)

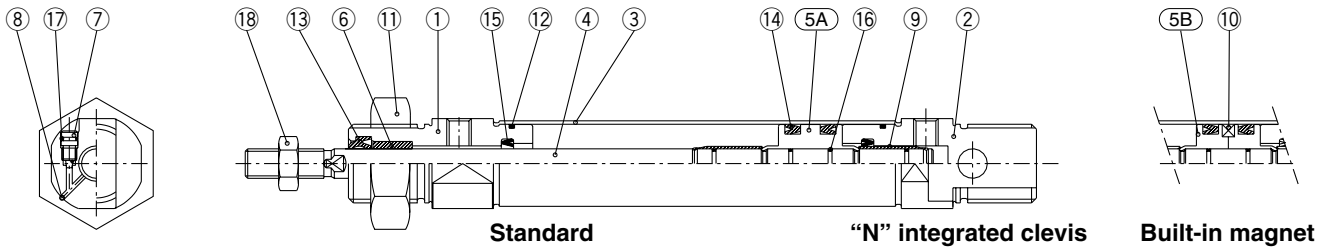

Component Parts

No.	Description	Material	Qty.	Note
①	Rod cover	Aluminum alloy	1	White anodized
②	Head cover N	Aluminum alloy	1	White anodized
③	Cylinder tube	Stainless steel	1	
④	Piston rod	Stainless steel	1	
⑤A	Piston A	Brass	1	
⑤B	Piston B	Brass	2	(Switch type piston)
⑥	Bush	Sintered bronze	1	
⑦	Cushion needle	Stainless steel	2	
⑧	Steel ball	Bearing steel	2	

No.	Description	Material	Qty.	Note
⑨	Cushion ring	Brass	2	
⑩	Magnet	Magnet	1	(Switch type only)
⑪	Mounting nut	Carbon steel	1	Nickel plating
⑫	Tube gasket	NBR	2	
⑬	Rod seal	NBR	1	
⑭	Piston seal	NBR	2	
⑮	Check seal	NBR	2	
⑯	Piston gasket and cushion ring gasket	NBR	3	(4 for switch type)
⑰	Needle seal	NBR	2	
⑱	Rod end nut	Carbon steel	1	Nickel plating

C□85□20/25 Air cushion

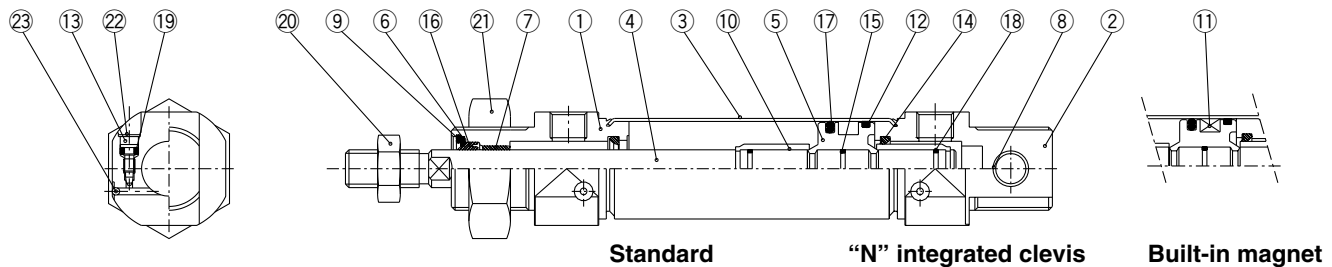

Component Parts

No.	Description	Material	Qty.	Note
①	Rod cover	Aluminum alloy	1	White anodized
②	Head cover N	Aluminum alloy	1	White anodized
③	Cylinder tube	Stainless steel	1	
④	Piston rod	Carbon steel	1	Hard chrome plated
⑤	Piston	Aluminum alloy	1	Chromate
⑥	Plain washer	Stainless steel	1	
⑦	Bush	Sintered bronze	1	
⑧	Bush	Sintered bronze	1	
⑨	Retaining ring	Carbon steel	1	Nickel plating
⑩	Cushion ring	Brass	2	
⑪	Magnet	Magnet	1	(Switch type only)
⑫	Wear ring	Resin	1	

No.	Description	Material	Qty.	Note
⑬	Cushion needle	Alloy steel	2	Electroless nickle plating
⑭	Cushion seal	Urethane	2	
⑮	Piston gasket	NBR	1	
⑯	Rod seal	NBR	1	
⑰	Piston seal	NBR	1	
⑱	Cushion ring gasket	NBR	2	
⑲	Cushion needle seal	NBR	2	
⑳	Rod end nut	Carbon steel	1	Nickel plating
㉑	Mounting nut	Carbon steel	1	Nickel plating
㉒	Self locking ring	Stainless steel	2	
㉓	Steel ball	Stainless steel	2	

ISO Cylinder: Standard/Non-rotating Type Double Acting, Single/Double Rod **Series C85**

Construction

[First angle projection]

Double acting, Double rod

C□85WE8 to 16 Rubber cushion (Disassembly is not possible.)

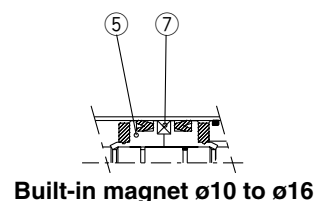
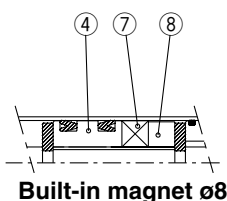
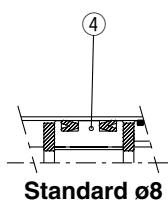
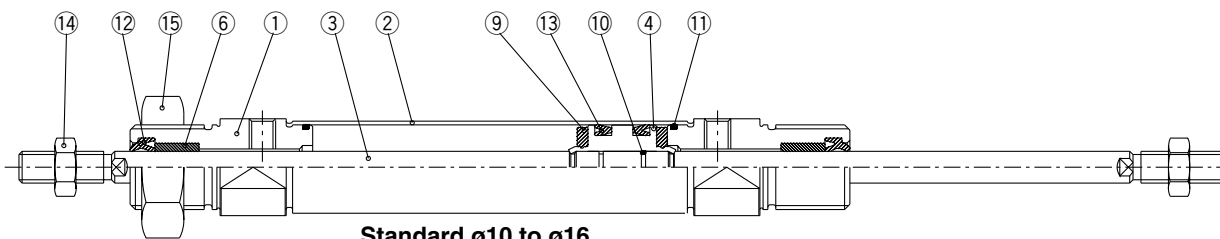

Component Parts

No.	Description	Material	Qty.	Note
①	Rod cover	Aluminum alloy	2	White anodized
②	Cylinder tube	Stainless steel	1	
③	Piston rod	Stainless steel	1	2 for ø8
④	Piston A	Brass	1	
⑤	Piston B	Brass	2	(Switch type piston)
⑥	Bush	Sintered bronze	2	
⑦	Magnet	Magnet	1	(Switch type only)
⑧	Spacer	Brass	1	

No.	Description	Material	Qty.	Note
⑨	Bumper	Urethane	2	
⑩	Piston gasket	NBR	1	(2 for switch type)
⑪	Tube gasket	NBR	2	
⑫	Rod seal	NBR	2	
⑬	Piston seal	NBR	2	
⑭	Rod end nut	Carbon steel	2	Nickel plating
⑮	Mounting nut	Carbon steel	1	Nickel plating

C□85WE20/25 Rubber bumper

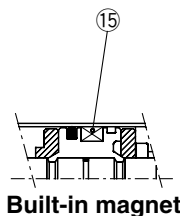
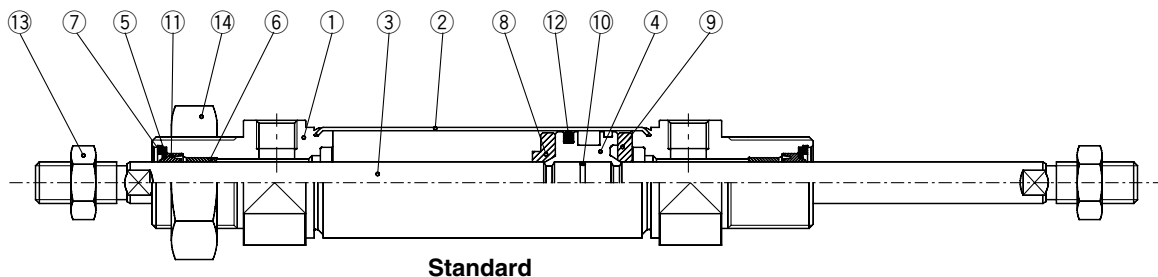

Component Parts

No.	Description	Material	Qty.	Note
①	Rod cover	Aluminum alloy	2	White anodized
②	Cylinder tube	Stainless steel	1	
③	Piston rod	Carbon steel	1	Hard chrome plated
④	Piston	Aluminum alloy	1	Chromate
⑤	Plain washer	Stainless steel	2	
⑥	Bush	Sintered bronze	2	
⑦	Retaining ring	Carbon steel	2	Nickel plating
⑧	Bumper A	Urethane	1	

No.	Description	Material	Qty.	Note
⑨	Bumper B	Urethane	1	
⑩	Piston gasket	NBR	1	
⑪	Rod seal	NBR	2	
⑫	Piston seal	NBR	1	
⑬	Rod end nut	Carbon steel	2	Nickel plating
⑭	Mounting nut	Carbon steel	1	Nickel plating
⑮	Magnet	Magnet	1	(Switch type only)

- CJ1
- CJP
- CJ2
- CM2
- CG1
- MB
- MB1
- CA2
- CS1
- C76
- C85**
- C95
- CP95
- NCM
- NCA
- D-
- X
- 20-
- Data

Series C85

Construction

[First angle projection]

Double acting, Double rod

C□85WE10 to 16 Air cushion (Disassembly is not possible.)

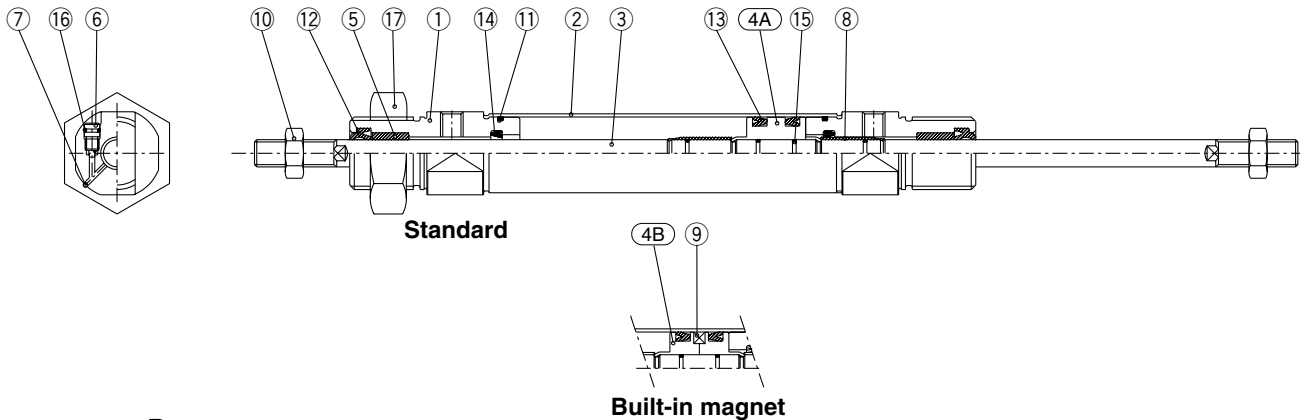

Component Parts

No.	Description	Material	Qty.	Note
①	Rod cover	Aluminum alloy	2	White anodized
②	Cylinder tube	Stainless steel	1	
③	Piston rod	Stainless steel	1	
④A	Piston A	Brass	1	
④B	Piston B	Brass	2	(Switch type piston)
⑤	Bush	Sintered bronze	2	
⑥	Cushion needle	Stainless steel	2	
⑦	Steel ball	Bearing steel	2	
⑧	Cushion ring	Brass	2	

No.	Description	Material	Qty.	Note
⑨	Magnet	Magnet	1	(Switch type only)
⑩	Rod end nut	Carbon steel	2	Nickel plating
⑪	Tube gasket	NBR	2	
⑫	Rod seal	NBR	2	
⑬	Piston seal	NBR	2	
⑭	Check seal	NBR	2	
⑮	Piston gasket and cushion ring gasket	NBR	3	(4 for switch type)
⑯	Needle seal	NBR	2	
⑰	Mounting nut	Carbon steel	2	Nickel plating

C□85WE 20/25 Air cushion

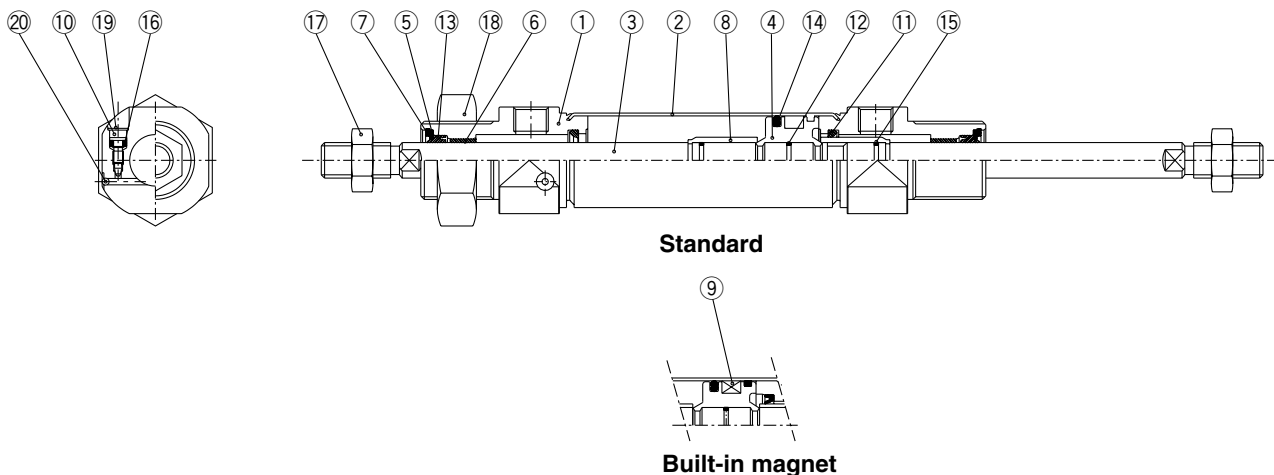

Component Parts

No.	Description	Material	Qty.	Note
①	Rod cover	Aluminum alloy	2	White anodized
②	Cylinder tube	Stainless steel	1	
③	Piston rod	Carbon steel	1	Hard chrome plated
④	Piston	Aluminum alloy	1	Chromated
⑤	Plain washer	Stainless steel	2	
⑥	Bush	Sintered bronze	2	
⑦	Retaining ring	Carbon steel	2	Nickel plating
⑧	Cushion ring	Brass	2	
⑨	Magnet	Magnet	1	(Switch type only)
⑩	Cushion needle	Alloy steel	2	Electroless nickel plating

No.	Description	Material	Qty.	Note
⑪	Cushion seal	Urethane	2	
⑫	Piston gasket	NBR	1	
⑬	Rod seal	NBR	2	
⑭	Piston seal	NBR	1	
⑮	Cushion ring gasket	NBR	2	
⑯	Cushion needle seal	NBR	2	
⑰	Rod end nut	Carbon steel	2	Nickel plating
⑱	Mounting nut	Carbon steel	1	Nickel plating
⑲	Self locking ring	Stainless steel	2	
⑳	Steel ball	Stainless steel	2	

ISO Cylinder: Standard/Non-rotating Type Double Acting, Single/Double Rod **Series C85**

Dimensions

[First angle projection]

Double acting, Single rod
Rubber cushion: C□85N Bore—Stroke—□
Without magnet, Built-in magnet

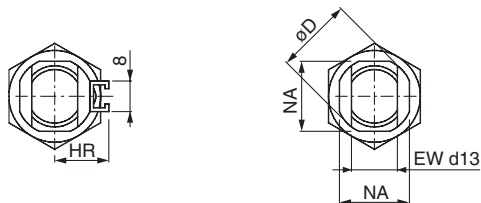

Rail mounting type (A) **Band mounting type (B)**
 or non-magnet

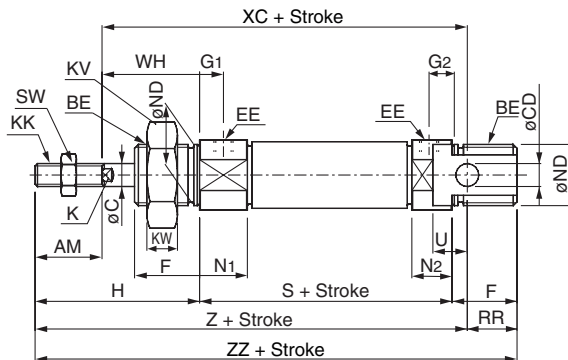

Air cushion: C□85N Bore—Stroke C—□
Without magnet, Built-in magnet

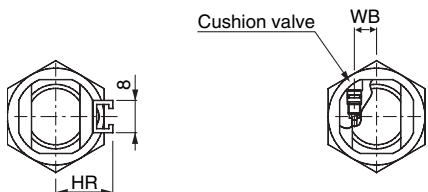

Rail mounting type (A) **Band mounting type (B)**
 or non-magnet

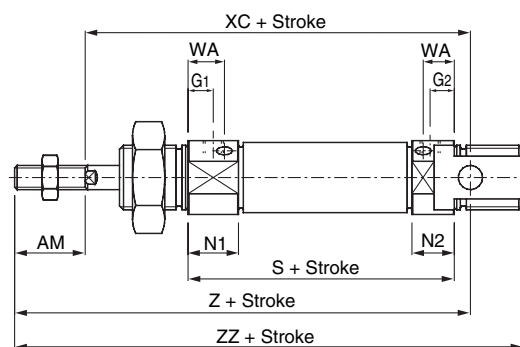

With rod boot

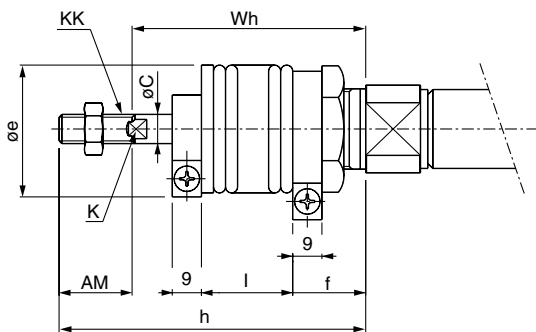

C□85KN
Non-rotating, Piston rod (Rubber cushion only)

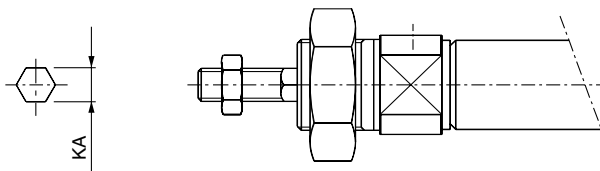

Rod cross section

Bore	AM	BE	øC	øCD H9	øD	EE	EW	F	G1	G2	WA	WB	H	HR	K	KA	KK	KV	KW	N1	N2	øND h8	RR	S	SW	U	WH	XC	Z	ZZ	
8	12	M12 x 1.25	4	4H9	16.7	M5 x 0.8	8	12	7	5	—	—	28	10	—	4.2	M4 x 0.7	19	6	11.5	9.5	15	12	10	46	7	6	16	64	76	86
10	12	M12 x 1.25	4	4H9	16.7	M5 x 0.8	8	12	7 (5.5)	5 (5.5)	10.5	4.5	28	10.5	—	4.2	M4 x 0.7	19	6	11.5 (13.5)	9.5 (13.5)	15	12	10	46 (53)	7	6	16	64 (71)	76 (83)	86 (93)
12	16	M16 x 1.5	6	6H9	19.7	M5 x 0.8	12	17	8 (5.5)	6 (5.5)	9.5	5.5	38	14	5	6.2	M6 x 1	24	8	12.5 (12.5)	10.5 (12.5)	18.3	16	14	50 (54)	10	9	22	75 (79)	91 (95)	105 (109)
16	16	M16 x 1.5	6	6H9	19.7	M5 x 0.8	12	17	8 (5.5)	6 (5.5)	9.5	5.5	38	14	5	6.2	M6 x 1	24	8	12.5 (12.5)	10.5 (12.5)	18.3	16	13	56 (56)	10	9	22	82 (82)	98 (98)	111 (111)
20	20	M22 x 1.5	8	8	28	G 1/8	16	20	8	8	11.5 (13)	8.5	44	17	6	8.2	M8 x 1.25	32	11	15 (17)	15 (17)	24	22	11	62	13	12	24	95	115	126
25	22	M22 x 1.5	10	8	33.5	G 1/8	16	22	8	8	11.5 (13)	10.5	50	20	8	10.2	M10 x 1.25	32	11	15 (17)	15 (17)	30	22	11	65	17	12	28	104	126	137

(): In the case of air cushion.

With Rod Boot

Bore	Stroke	AM	øC	øe	f	K	KK	h						
								1 to 50	51 to 100	101 to 150	151 to 200	201 to 300	301 to 400	401 to 500
20	20	20	8	36	20	6	M8 x 1.25	71	84	96	109	134	159	—
25	22	22	10	36	20	8	M10 x 1.25	74	87	99	112	137	162	187

Bore	Stroke	l							Wh						
		1 to 50	51 to 100	101 to 150	151 to 200	201 to 300	301 to 400	401 to 500	1 to 50	51 to 100	101 to 150	151 to 200	201 to 300	301 to 400	401 to 500
20	20	12.5	25	37.5	50	75	100	—	51	64	76	89	114	139	—
25	22	12.5	25	37.5	50	75	100	125	52	65	77	90	115	140	165

- CJ1
- CJP
- CJ2
- CM2
- CG1
- MB
- MB1
- CA2
- CS1
- C76
- C85**
- C95
- CP95
- NCM
- NCA
- D-
- X
- 20-
- Data

Series C85

Dimensions

[First angle projection]

Double acting, Single rod

Rubber cushion: C□85E Bore Stroke

Without magnet, Built-in magnet

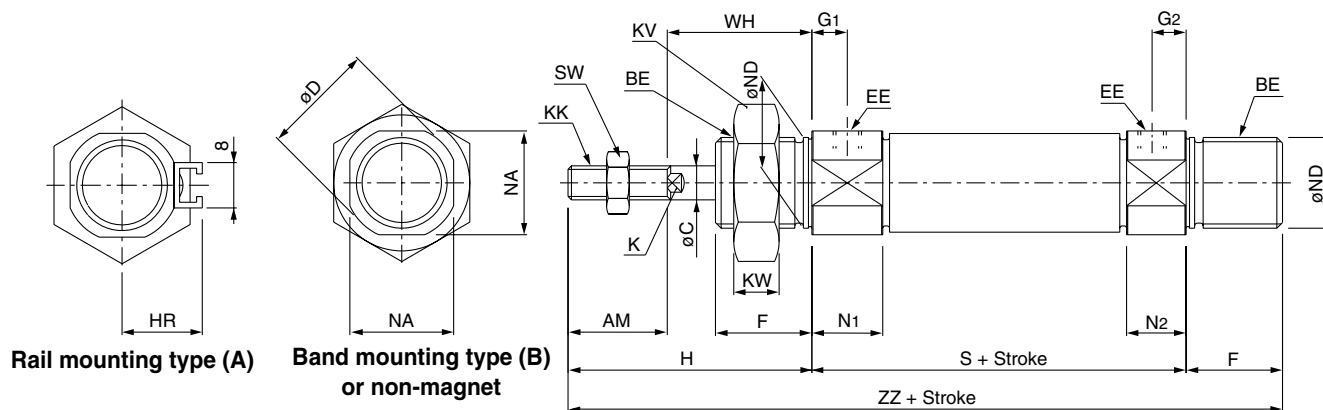

With rod boot

C□85KE

Non-rotating, Piston rod (Rubber cushion only)

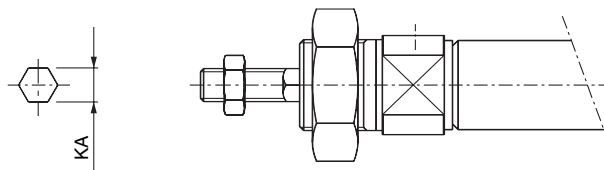
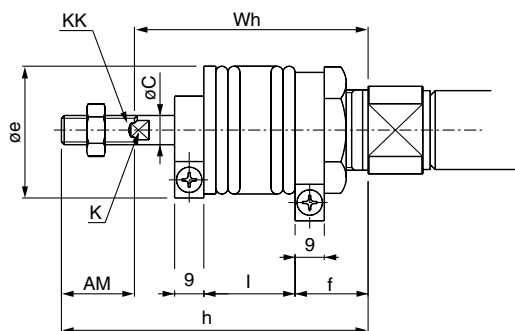

Rod cross section

Bore	AM	BE	øC	øD	EE	F	G1	G2	H	HR	K	KA	KK	KV	KW	N1	N2	NA	øND h8	S	SW	WH	ZZ
8	12	M12 x 1.25	4	16.7	M5 x 0.8	12	7	5	28	10	—	4.2	M4 x 0.7	19	6	11.5	9.5	15	12	46	7	16	86
10	12	M12 x 1.25	4	16.7	M5 x 0.8	12	7	5	28	10.5	—	4.2	M4 x 0.7	19	6	11.5	9.5	15	12	46	7	16	86
12	16	M16 x 1.5	6	19.7	M5 x 0.8	17	8	6	38	14	5	6.2	M6 x 1	24	8	12.5	10.5	18.3	16	50	10	22	105
16	16	M16 x 1.5	6	19.7	M5 x 0.8	17	8	6	38	14	5	6.2	M6 x 1	24	8	12.5	10.5	18.3	16	56	10	22	111
20	20	M22 x 1.5	8	28	G 1/8	20	8	8	44	17	6	8.2	M8 x 1.25	32	11	15	15	24	22	62	13	24	126
25	22	M22 x 1.5	10	33.5	G 1/8	22	8	8	50	20	8	10.2	M10 x 1.25	32	11	15	15	30	22	65	17	28	137

(mm)

With Rod Boot

(mm)

Item Bore \ Stroke	AM	øC	øe	f	K	KK	h						
							1 to 50	51 to 100	101 to 150	151 to 200	201 to 300	301 to 400	401 to 500
20	20	8	36	20	6	M8 x 1.25	71	84	96	109	134	159	—
25	22	10	36	20	8	M10 x 1.25	74	87	99	112	137	162	187

Item Bore \ Stroke	l							Wh						
	1 to 50	51 to 100	101 to 150	151 to 200	201 to 300	301 to 400	401 to 500	1 to 50	51 to 100	101 to 150	151 to 200	201 to 300	301 to 400	401 to 500
20	12.5	25	37.5	50	75	100	—	51	64	76	89	114	139	—
25	12.5	25	37.5	50	75	100	125	52	65	77	90	115	140	165

ISO Cylinder: Standard/Non-rotating Type Double Acting, Single/Double Rod **Series C85**

Dimensions with Mounting Bracket

[First angle projection]

Double acting, Single rod

Rod foot, Rod and head foot: C85L10^A, C85L16^A, C85L25^A

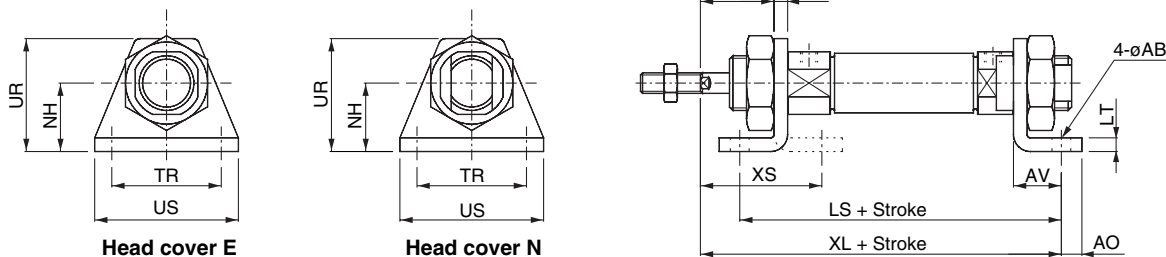

Rod flange, Head flange: C85F10, C85F16, C85F25

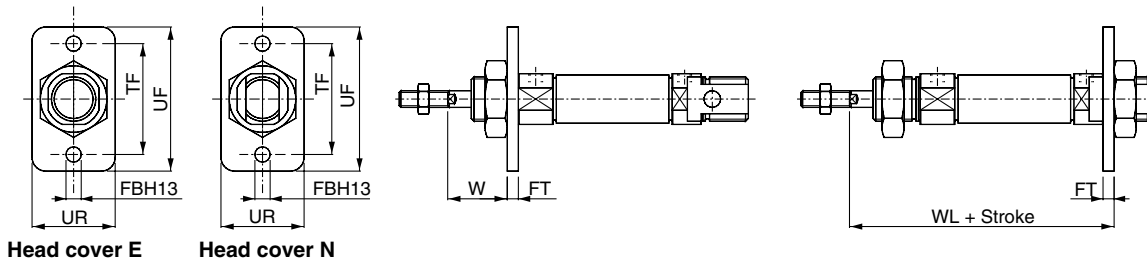

Rod trunnion, Head trunnion: C85T10, C85T16, C85T25

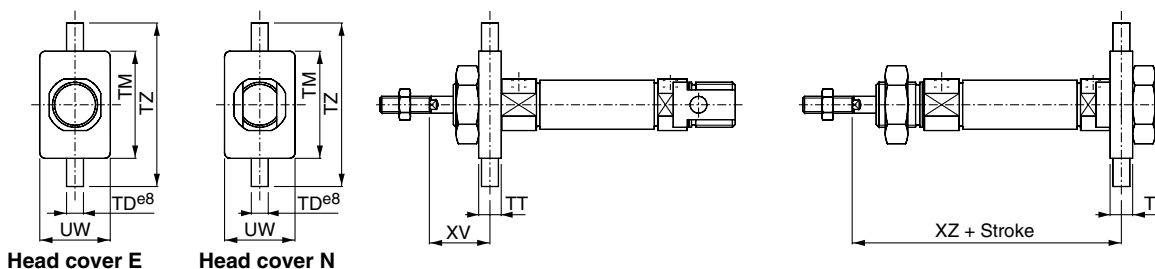

Clevis: C85C10, C85C16, C85C25

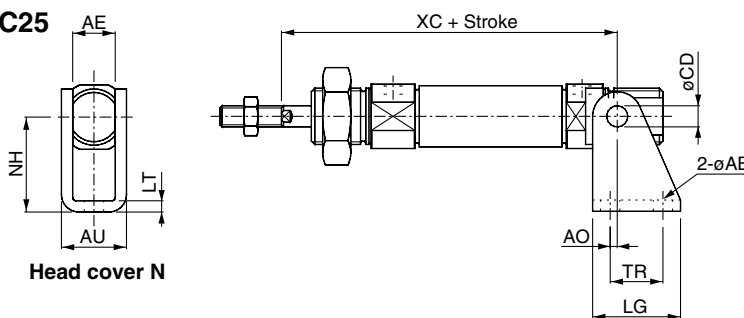

Bore	Rod foot, Rod and head foot												Rod flange, Head flange							
	AO	US	øAB	LT	NH	LS	XL	TR JS14	XS	AV	UR	W	UR	FBH13	FT	TF	UF	W	WL	
8	5	35	4.5	3.2	16	68	73	25	23.8	11	26	12.8	22	4.5	3.2	30	40	12.8	65.2	
10	5	35	4.5	3.2	16	68(75)	73(80)	25	23.8	11	26	12.8	22	4.5	3.2	30	40	12.8	65.2(72.2)	
12	6	42	5.5	4	20	78(82)	86(90)	32	32	14	33	18	30	5.5	4	40	52	18	76(80)	
16	6	42	5.5	4	20	84(84)	92(92)	32	32	14	33	18	30	5.5	4	40	52	18	82(82)	
20	8	54	6.6	5	25	96	103	40	36	17	42	19	40	6.6	5	50	66	19	91	
25	8	54	6.6	5	25	99	110	40	40	17	42	23	40	6.6	5	50	66	23	98	

Bore	Rod trunnion, Head trunnion							Clevis									
	TT	UW	øTD ø8	TM	TZ	XV	XZ	øCD H9	AE	øAB	AO	AU	TR	LG	NH	LT	XC
8	6	20	4	26	38	13	65	4	8.1	4.5	1.5	13.1	12.5	20	24	2.5	64
10	6	20	4	26	38	13	65(72)	4	8.1	4.5	1.5	13.1	12.5	20	24	2.5	64(71)
12	8	25	6	38	58	18	76(80)	6	12.1	5.5	2	18.5	15	25	27	3.2	75(79)
16	8	25	6	38	58	18	82(82)	6	12.1	5.5	2	18.5	15	25	27	3.2	82(82)
20	8	32	6	46	66	20	90	8	16.1	6.6	4	24.1	20	32	30	4	95
25	8	32	6	46	66	24	97		16.1	6.6	4	24.1	20	32	30	4	104

(): In the case of air cushion.

- CJ1
- CJP
- CJ2
- CM2
- CG1
- MB
- MB1
- CA2
- CS1
- C76
- C85**
- C95
- CP95
- NCM
- NCA
- D-
- X
- 20-
- Data

Series C85

Dimensions

[First angle projection]

Double acting, Single rod

Rubber cushion: C□85F/Y **Bore** **Stroke** □

Without magnet, Built-in magnet

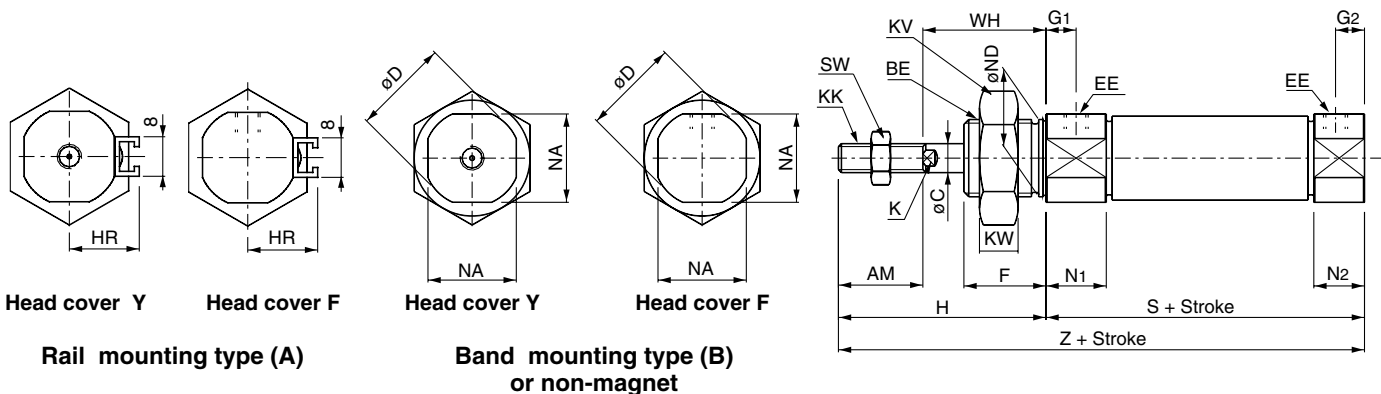

With rod boot

C□85KF/Y **Bore** **Stroke**

Non-rotating, Piston rod (Rubber cushion only)

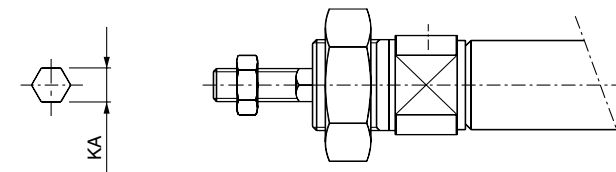
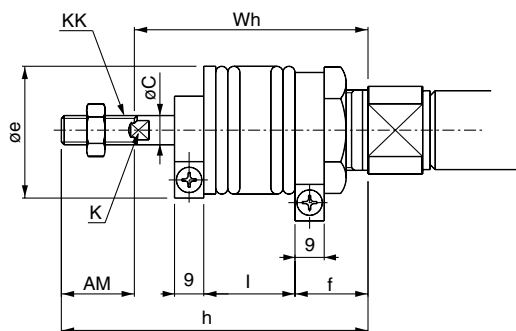

(mm)

Bore	AM	BE	øC	øD	EE	F	G1	G2	H	HR	K	KA	KK	KV	KW	N1	N2	NA	øND h8	S	SW	WH	Z
8	12	M12 x 1.25	4	16.7	M5 x 0.8	12	7	5	28	10	—	4.2	M4 x 0.7	19	6	11.5	9.5	15	12	46	7	16	74
10	12	M12 x 1.25	4	16.7	M5 x 0.8	12	7	5	28	10.5	—	4.2	M4 x 0.7	19	6	11.5	9.5	15	12	46	7	16	74
12	16	M16 x 1.5	6	19.7	M5 x 0.8	17	8	6	38	14	5	6.2	M6 x 1	24	8	12.5	10.5	18.3	16	50	10	22	88
16	16	M16 x 1.5	6	19.7	M5 x 0.8	17	8	6	38	14	5	6.2	M6 x 1	24	8	12.5	10.5	18.3	16	50	10	22	88
20	20	M22 x 1.5	8	28	G 1/8	20	8	8	44	17	6	8.2	M8 x 1.25	32	11	15	15	24	22	62	13	24	106
25	22	M22 x 1.5	10	33.5	G 1/8	22	8	8	50	20	8	10.2	M10 x 1.25	32	11	15	15	30	22	65	17	28	115

With Rod Boot

(mm)

Bore	Item Stroke	AM	øC	øe	f	K	KK	h						
								1 to 50	51 to 100	101 to 150	151 to 200	201 to 300	301 to 400	401 to 500
20	20	20	8	36	20	6	M8 x 1.25	71	84	96	109	134	159	—
25	22	22	10	36	20	8	M10 x 1.25	74	87	99	112	137	162	187

Bore	Item Stroke	l							Wh						
		1 to 50	51 to 100	101 to 150	151 to 200	201 to 300	301 to 400	401 to 500	1 to 50	51 to 100	101 to 150	151 to 200	201 to 300	301 to 400	401 to 500
20	20	12.5	25	37.5	50	75	100	—	51	64	76	89	114	139	—
25	22	12.5	25	37.5	50	75	100	125	52	65	77	90	115	140	165

ISO Cylinder: Standard/Non-rotating Type
Double Acting, Single/Double Rod **Series C85**

Dimensions with Mounting Bracket

[First angle projection]

Double acting, Single rod
Rod foot: C85L10A, C85L16A, C85L25A

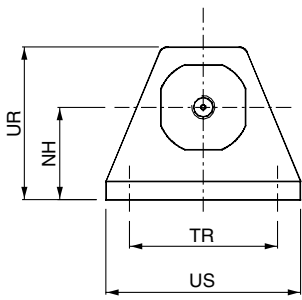

Head cover Y

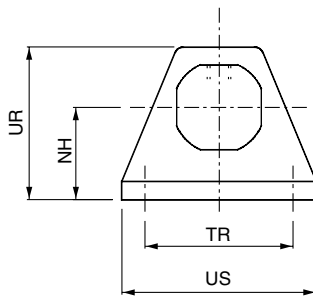

Head cover F

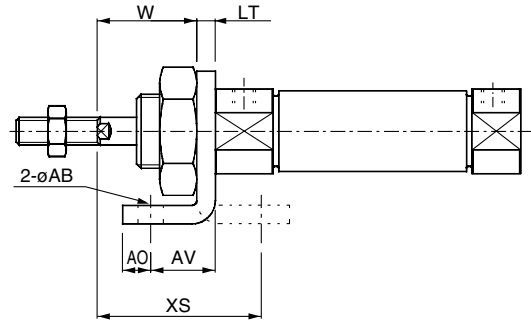

Rod flange: C85F10, C85F16, C85F25

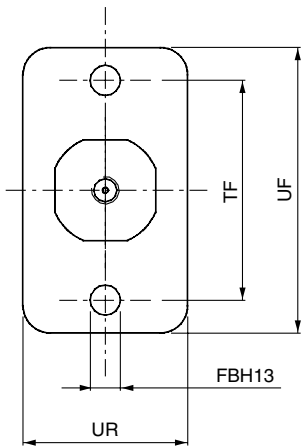

Head cover Y

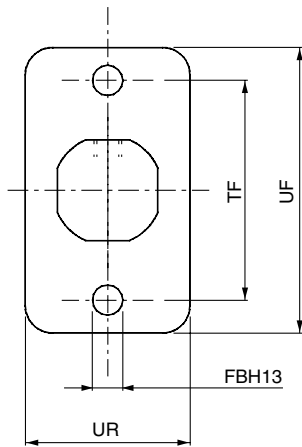

Head cover F

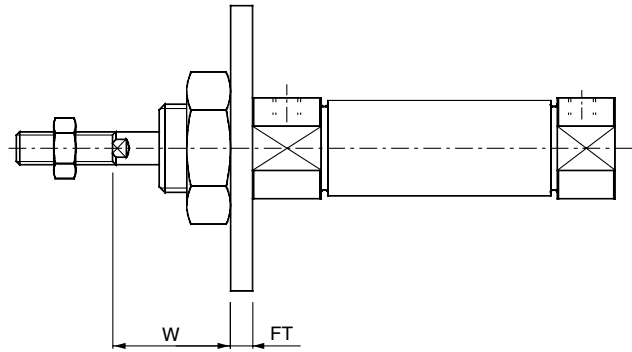

Rod trunnion: C85T10, C85T16, C85T25

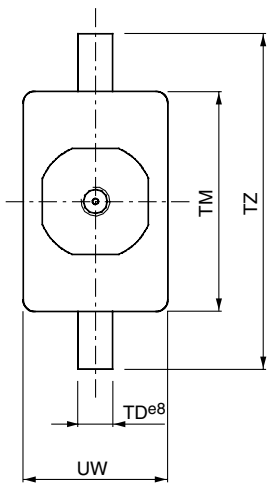

Head cover Y

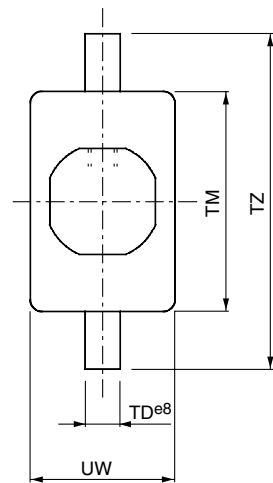

Head cover F

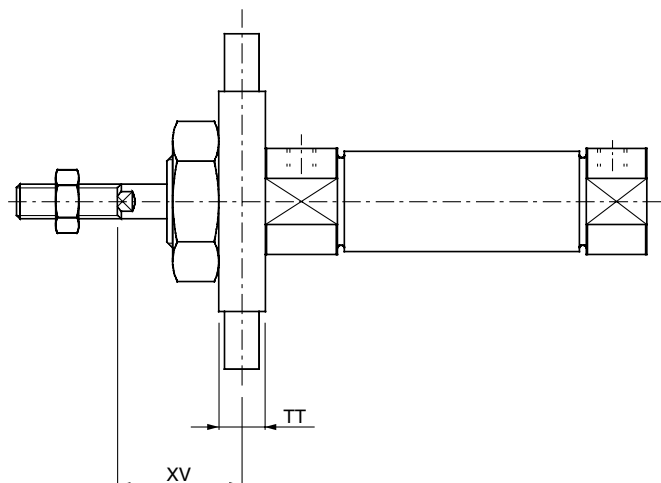

- CJ1
- CJP
- CJ2
- CM2
- CG1
- MB
- MB1
- CA2
- CS1
- C76
- C85**
- C95
- CP95
- NCM
- NCA
- D-
- X
- 20-
- Data

Bore	Rod foot											Rod flange					Rod trunnion						
	AO	US	øAB	LT	NH	TR	JS14	XS	AV	UR	W	UR	FBH13	FT	TF	UF	W	TT	UW	TD e8	TM	TZ	XV
8	5	35	4.5	3.2	16	25	25	23.8	11	26	12.8	22	4.5	3.2	30	40	12.8	6	20	4	26	38	13
10	5	35	4.5	3.2	16	25	23.8	11	26	12.8	22	4.5	3.2	30	40	12.8	6	20	4	26	38	13	
12	6	42	5.5	4	20	32	32	14	33	18	30	5.5	4	40	52	18	8	25	6	38	58	18	
16	6	42	5.5	4	20	32	32	14	33	18	30	5.5	4	40	52	18	8	25	6	38	58	18	
20	8	54	6.6	5	25	40	36	17	42	19	40	6.6	5	50	66	19	8	32	6	46	66	20	
25	8	54	6.6	5	25	40	40	17	42	23	40	6.6	5	50	66	23	8	32	6	46	66	24	

Series C85

Dimensions

[First angle projection]

Double acting, Double rod
 Rubber cushion: C□85WE Bore — Stroke □
 Without magnet, Built-in magnet

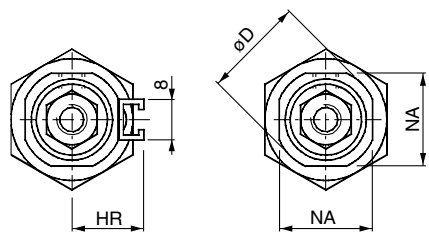

Rail mounting type (A) Band mounting type (B) or non-magnet

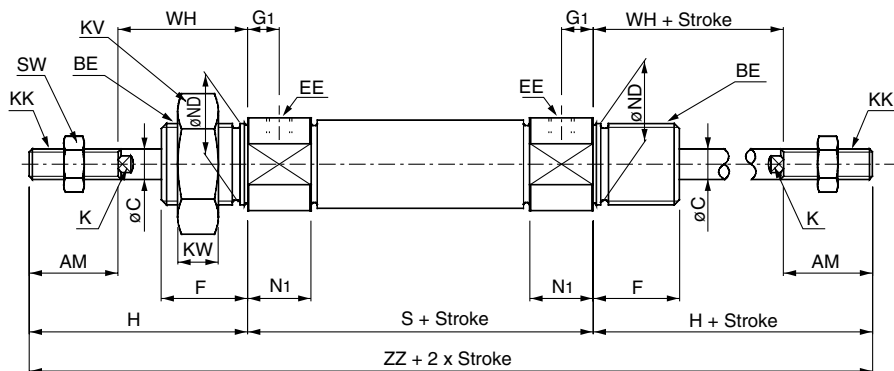

Air Cushion: C□85WE Bore — Stroke C-□
 Without magnet, Built-in magnet

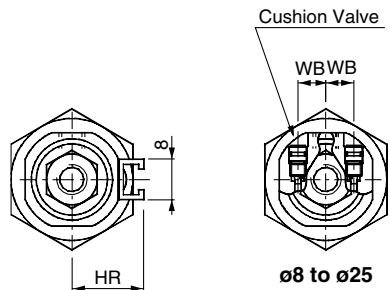

Rail mounting type (A) Band mounting type (B) or non-magnet

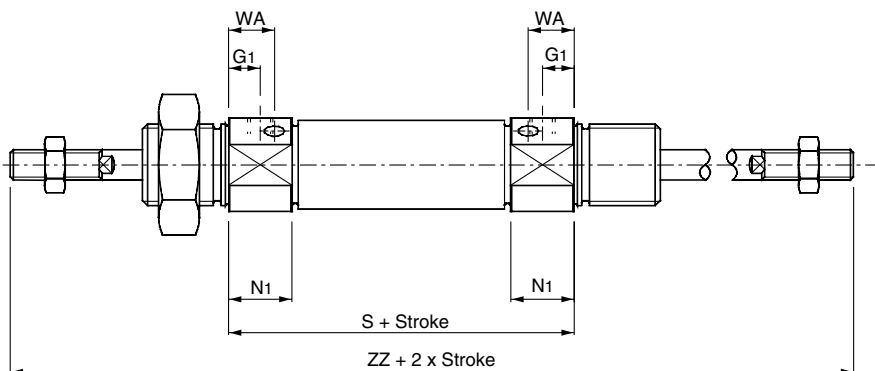

With rod boot

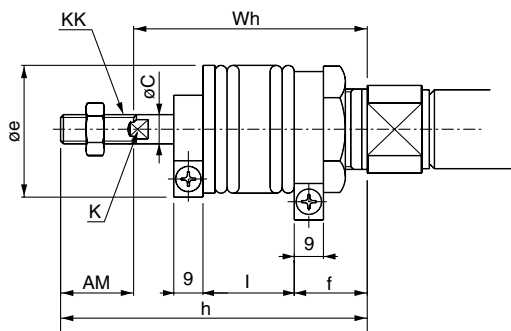

(mm)

Bore	AM	BE	øC	øD	EE	F	G1	WA	WB	H	HR	K	KK	KV	KW	N1	NA	øND h8	S	SW	WH	ZZ
8	12	M12 x 1.25	4	16.7	M5 x 0.8	12	7	—	—	28	10	—	M4 x 0.7	19	6	11.5	15	12	48(54)	7	16	104(110)
10	12	M12 x 1.25	4	16.7	M5 x 0.8	12	7(5.5)	10.5	4.5	28	10.5	—	M4 x 0.7	19	6	11.5(13.5)	15	12	48(53)	7	16	104(109)
12	16	M16 x 1.5	6	19.7	M5 x 0.8	17	8(5.5)	9.5	5.5	38	14	5	M6 x 1	24	8	12.5(12.5)	18.3	16	52(54)	10	22	128(130)
16	16	M16 x 1.5	6	19.7	M5 x 0.8	17	8(5.5)	9.5	5.5	38	14	5	M6 x 1	24	8	12.5(12.5)	18.3	16	52(54)	10	22	128(130)
20	20	M22 x 1.5	8	28	G 1/8	20	8	11.5(13)	8.5	44	17	6	M8 x 1.25	32	11	15(17)	24	22	62	13	24	150
25	22	M22 x 1.5	10	33.5	G 1/8	22	8	11.5(13)	10.5	50	20	8	M10 x 1.25	32	11	15(17)	30	22	65	17	28	165

() : In the case of air cushion. { } : In the case of built-in magnet

With Rod Boot

(mm)

Bore	Item Stroke	AM	øC	øe	f	K	KK	h						
								1 to 50	51 to 100	101 to 150	151 to 200	201 to 300	301 to 400	401 to 500
20		20	8	36	20	6	M8 x 1.25	71	84	96	109	134	159	—
25		22	10	36	20	8	M10 x 1.25	74	87	99	112	137	162	187

Bore	Item Stroke	l							Wh						
		1 to 50	50 to 100	101 to 150	151 to 200	201 to 300	301 to 400	401 to 500	1 to 50	51 to 100	101 ~ 150	151 ~ 200	201 ~ 300	301 ~ 400	401 ~ 500
20		12.5	25	37.5	50	75	100	—	51	64	76	89	114	139	—
25		12.5	25	37.5	50	75	100	125	52	65	77	90	115	140	165

ISO Cylinder: Standard/Non-rotating Type Double Acting, Single/Double Rod **Series C85**

Dimensions with Mounting Bracket

[First angle projection]

Double acting, Double rod

Rod foot, Rod and head foot: C85L10^A, C85L16^A, C85L25^A

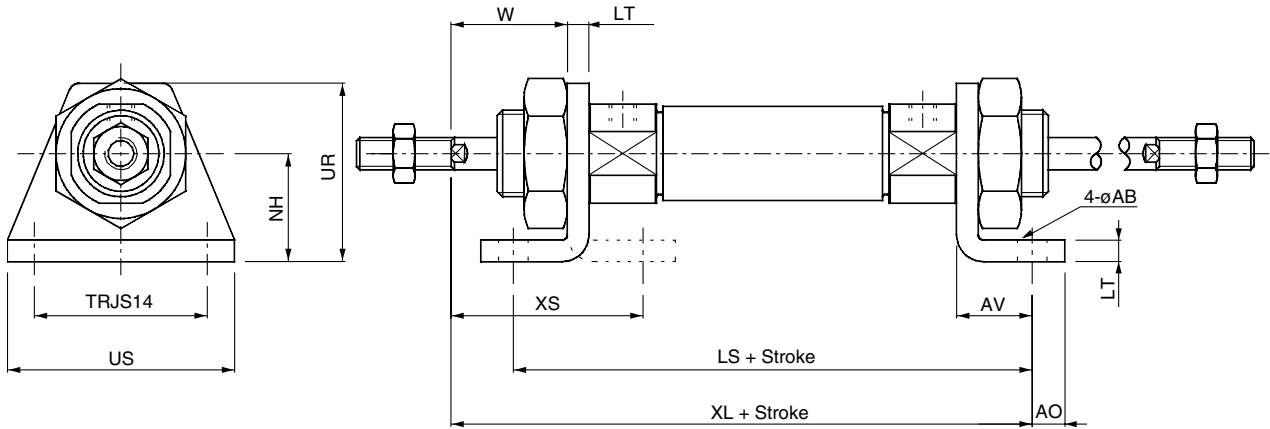

Flange: C85F10, C85F16, C85F25

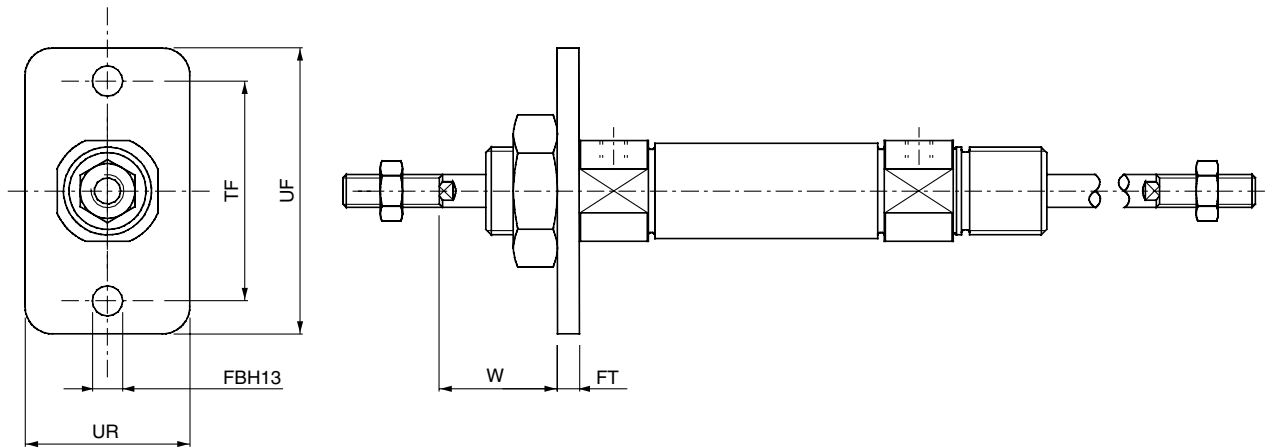

Trunnion: C85T10, C85T16, C85T25

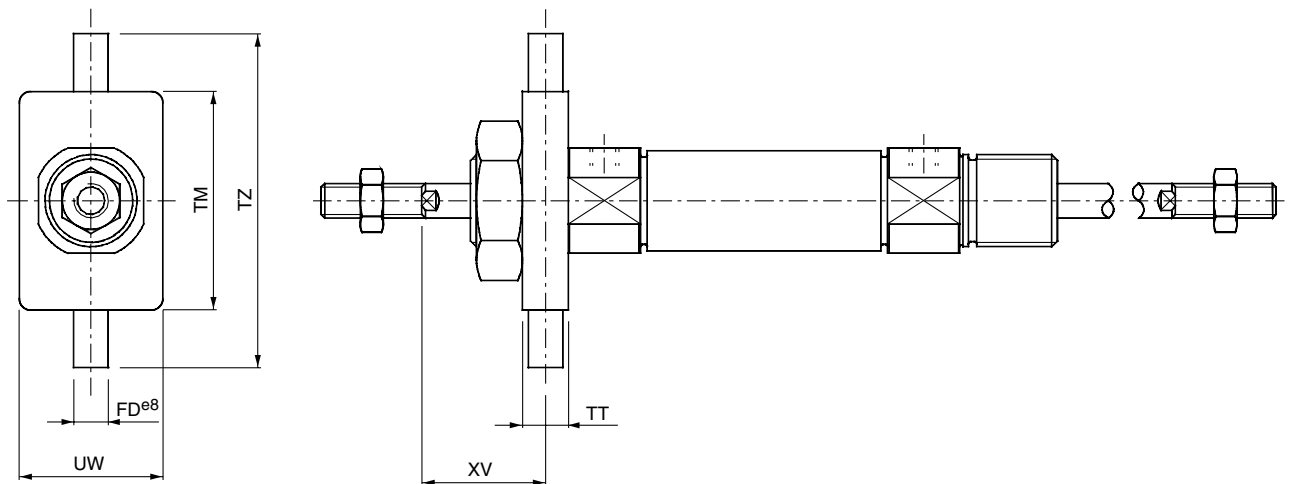

- CJ1
- CJP
- CJ2
- CM2
- CG1
- MB
- MB1
- CA2
- CS1
- C76
- C85**
- C95
- CP95
- NCM
- NCA
- D-
- X
- 20-
- Data

Bore	Rod foot, Rod and head foot											Flange						Trunnion						
	AO	US	øAB	LT	NH	LS	XL	TR JS14	XS	AV	UR	W	UR	FBH13	FT	TF	UF	W	TT	UW	TD e8	TM	TZ	XV
8	5	35	4.5	3.2	16	70{76}	75{81}	25	23.8	11	26	12.8	22	4.5	3.2	30	40	12.8	6	20	4	26	38	13
10	5	35	4.5	3.2	16	70{75}	75{80}	25	23.8	11	26	12.8	22	4.5	3.2	30	40	12.8	6	20	4	26	38	13
12	6	42	5.5	4	20	80{82}	88{90}	32	32	14	33	18	30	5.5	4	40	52	18	8	25	6	38	58	18
16	6	42	5.5	4	20	80{82}	88{90}	32	32	14	33	18	30	5.5	4	40	52	18	8	25	6	38	58	18
20	8	54	6.6	5	25	96	103	40	36	17	42	19	40	6.6	5	50	66	19	8	32	6	46	66	20
25	8	54	6.6	5	25	99	110	40	40	17	42	23	40	6.6	5	50	66	23	8	32	6	46	66	24

(): In the case of air cushion. { }: In the case of auto switch.

Series C85

Accessory Dimensions

[First angle projection]

Single Knuckle Joint/DIN648-DIN24335

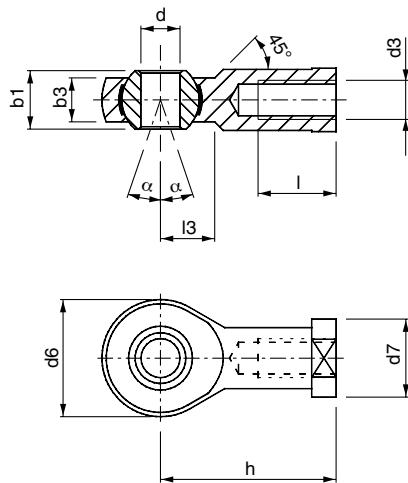

Double Knuckle Joint/ISO8140-DIN71752

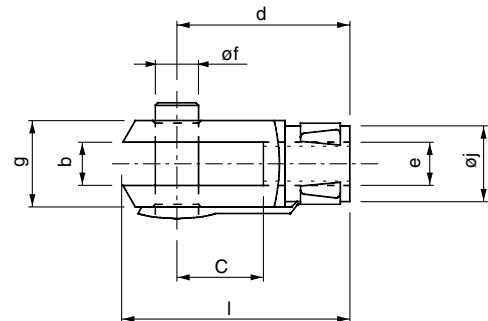

Bore	Model	Thread	d3	dh7	h	d6	b3	b1	l	d7	α°	l3
8	KJ4D	M4 x 0.7	5	27	18	6.0	8	10	11	7.5	10	
10	KJ4D	M4 x 0.7	5	27	18	6.0	8	10	11	7.5	10	
12	KJ6D	M6 x 1	6	30	20	6.75	9	12	13	6.5	10	
16	KJ6D	M6 x 1	6	30	20	6.75	9	12	13	6.5	10	
20	KJ8D	M8 x 1.25	8	36	24	9	12	16	16	13	12	
25	KJ10D	M10 x 1.25	10	43	28	10.5	14	20	19	13	14	

(mm)

Bore	Model	Thread	e	b	d	f	g	c	j	a
8	GKM4-8	M4 x 0.7	4	16	4	8	8	6	8	
10	GKM4-8	M4 x 0.7	4	16	4	8	8	6	8	
12	GKM6-12	M6 x 1	6	24	6	10	12	8	12	
16	GKM6-12	M6 x 1	6	24	6	10	12	8	12	
20	GKM8-16	M8 x 1.25	8	32	8	12	16	10	16	
25	GKM10-20	M10 x 1.25	10	40	10	18	20	12	20	

(mm)

Floating joint: Series JA

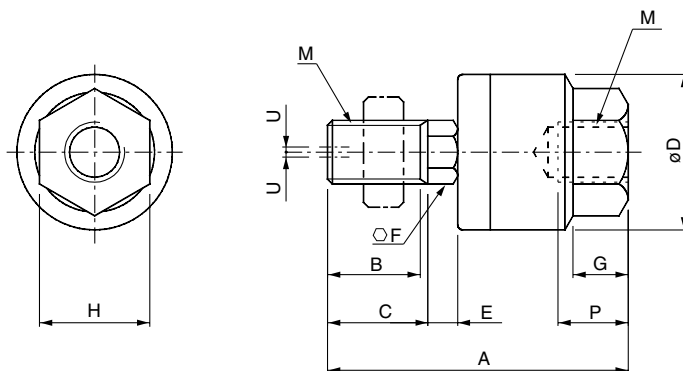

In the case of dimension without C

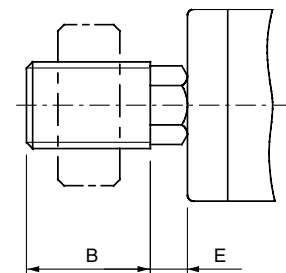

Bore	Model	M		A	B	C	D	E	F	G	H	Maximum screwed depth P	Allowable eccentricity U	Max. operating tension and compression power (kN)
		Nominal thread dia.	Pitch											
8, 10	JA10-4-070	4	0.7	26	9	10	12	1.5	4	4	7	5.5	0.5	0.054
12, 16	JA15-6-100	6	1	34.5	12.5	14	16	2	6	5	10	7	0.5	0.123
20	JA20-8-125	8	1.25	44	17.5	—	21	4.5	7	7	13	8	0.5	1.1
25	JA30-10-125	10	1.25	49.5	19.5	—	24	5	8	8	17	9	0.5	2.5

(mm)

ISO Cylinder: Standard/Non-rotating Type Double Acting, Single/Double Rod **Series C85**

Auto Switch Mounting Position and Mounting Height

[First angle projection]

Double acting, Single rod

(Band mounting type)

(Rail mounting type)

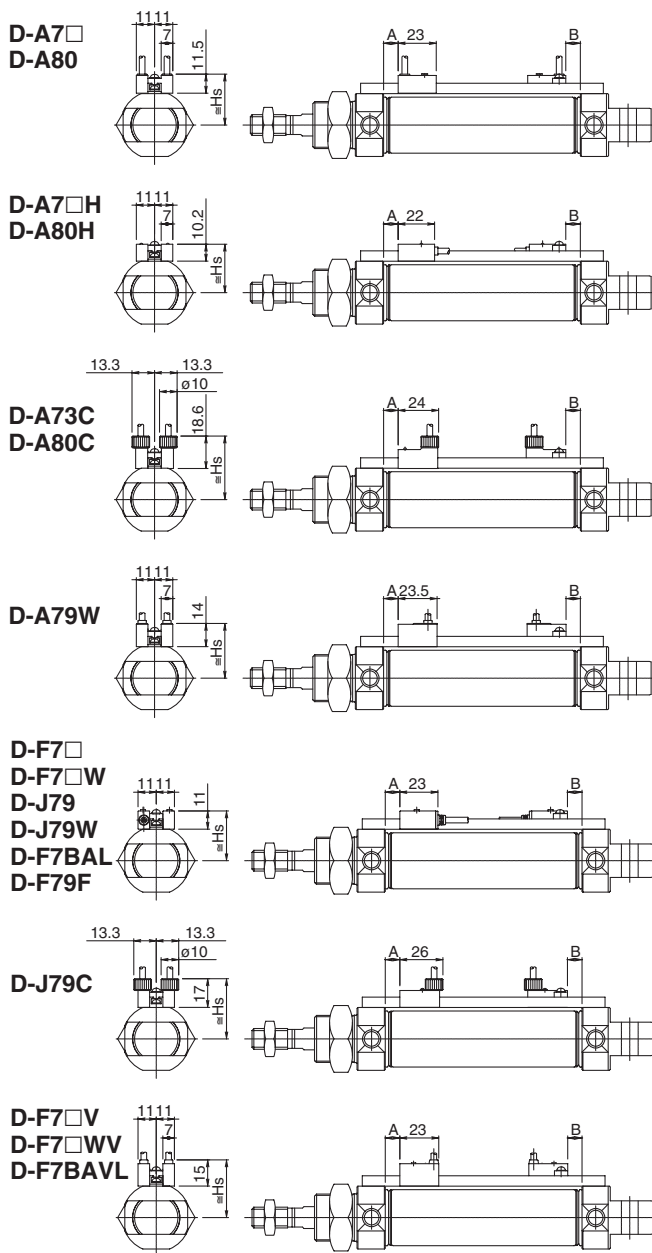
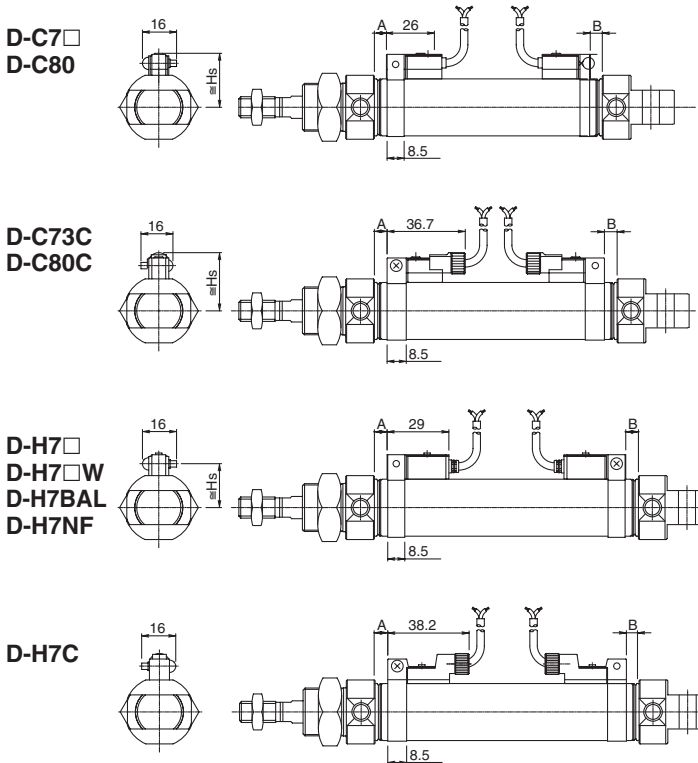

Auto Switch Mounting Position

(mm)

Bore	D-C7□ D-C80 D-C73C D-C80C		D-A73 D-A80		D-A7□H/A80H D-A73C/A80C D-F7□/J79 D-F7□W/J79W D-F7□V D-F7□WV D-J79C/A72 D-F7BAL D-F79F		D-H7□ D-H7□W D-H7BAL D-H7NF		D-A79W	
	A	B	A	B	A	B	A	B	A	B
8	3	3	3.5	3.5	4	4	2	2	—	—
10	3 (3.5)	3 (3.5)	3.5 (4)	3.5 (4)	4 (4.5)	4 (4.5)	2 (2.5)	2 (2.5)	—	—
12	4 (4.5)	4 (4.5)	4.5 (5.5)	4.5 (5.5)	5 (6)	5 (6)	3 (4)	3 (4)	—	—
16	4 (5)	10 (7) 4	4.5 (5.5)	10.5 (7.5) 4.5	5 (6)	11 (8) 5	3 (4)	9 (6) 3	2 (3)	8 (5) 2
20	7 (5)	6 (4)	7.5 (5.5)	6.5 (4.5)	8 (6)	7 (5)	6 (4)	5 (3)	5 (3)	4 (2)
25	8.5 (6.5)	7.5 (5.5)	9 (7)	8 (6)	9.5 (7.5)	8.5 (6.5)	7.5 (5.5)	6.5 (4.5)	6.5 (4.5)	5.5 (3.5)

- () for air cushion type.
- The lower of ø16 is a number for CD85F/Y.
- Aim at this number.

C85 Auto Switch Mounting Height

(mm)

Bore	D-C7□/C80 D-H7□ D-H7□W D-H7BAL D-H7NF	D-C73C D-C80C	D-A7□ D-A80	D-A7□H/A80H D-F7□/J79 D-F7□W/J79W D-F7BAL D-F79F	D-A73C D-A80C	D-H7C	D-A79W	D-J79C	D-F7□V D-F7□WV D-F7BALV
	Hs	Hs	Hs	Hs	Hs	Hs	Hs	Hs	Hs
8	16	18.5	18	19	25	19	—	23.5	21.5
10	17	19.5	18	19	25	20	—	23.5	21.5
12	18.5	21	19.5	20.5	26.5	21	—	25	23
16	20.5	23	19.5	20.5	26.5	23	22	25	23
20	22.5	25	22.5	23.5	29.5	25	25	29	26
25	25	27.5	25.5	26.5	32.5	27.5	28	32	29

- Aim at this number.

- CJ1
- CJP
- CJ2
- CM2
- CG1
- MB
- MB1
- CA2
- CS1
- C76
- C85**
- C95
- CP95
- NCM
- NCA
- D-
- X
- 20-
- Data

Series C85

Auto Switch Mounting Position and Mounting Height

[First angle projection]

Double acting, Double rod

(Band mounting type)

(Rail mounting type)

D-C7□
D-C80

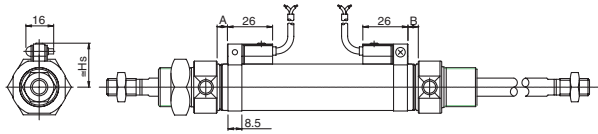

D-A7□
D-A80

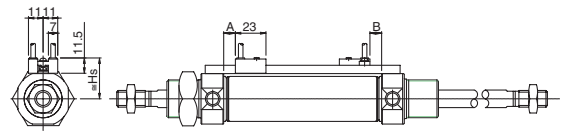

D-C73C
D-C80C

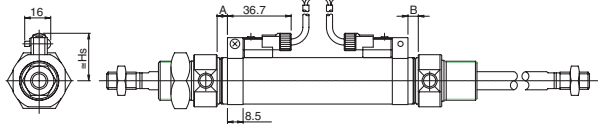

D-A7□H
D-A80H

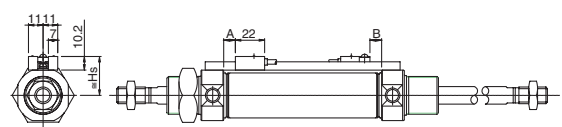

D-H7□
D-H7□W
D-H7BAL
D-H7NF

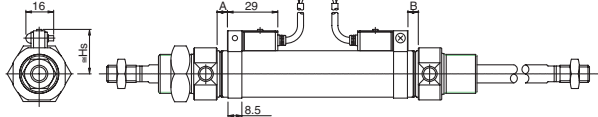

D-A73C
D-A80C

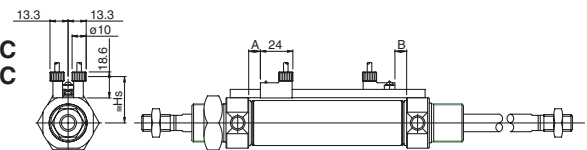

D-H7C

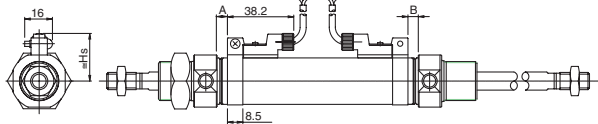

D-A79W

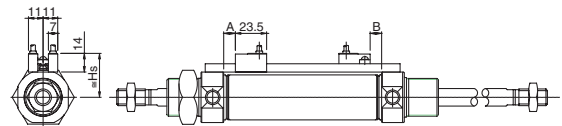

D-F7□
D-F7□W
D-J79
D-J79W
D-F7BAL
D-F79F

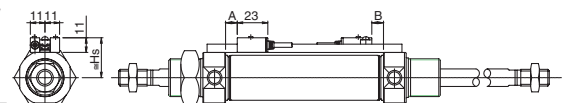

Auto Switch Mounting Position

(mm)

Bore	D-C7□ D-C80 D-C73C D-C80C		D-A73 D-A80		D-A7□H/A80H D-A73C/A80C D-F7□/J79 D-F7□W/J79W D-F7□V D-F7□WV D-J79C D-F7BAL D-F79F/A72		D-H7□ D-H7□W D-H7BAL D-H7NF		D-A79W	
	A	B	A	B	A	B	A	B	A	B
8	10	2	10.5	2.5	11	3	9	1	—	—
10	3 (3.5)	3 (3.5)	3.5 (4)	3.5 (4)	4 (4.5)	4 (4.5)	2 (2.5)	2 (2.5)	—	—
12	4 (4.5)	4 (4.5)	4.5 (5.5)	4.5 (5.5)	5 (6)	5 (6)	3 (4)	3 (4)	—	—
16	4 (5)	4 (5)	4.5 (5.5)	4.5 (5.5)	5 (6)	5 (6)	3 (4)	3 (4)	2 (3)	2 (3)
20	7 (5)	6 (4)	7.5 (5.5)	6.5 (4.5)	8 (6)	7 (5)	6 (4)	5 (3)	5 (3)	4 (2)
25	8.5 (6.5)	7.5 (5.5)	9 (7)	8 (6)	9.5 (7.5)	8.5 (6.5)	7.5 (5.5)	6.5 (4.5)	6.5 (4.5)	5.5 (3.5)

• () for air cushion type.

D-J79C

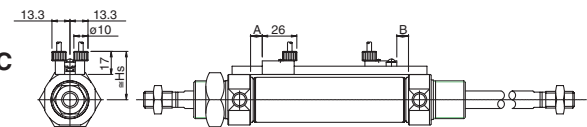

D-F7□V
D-F7□WV
D-F7BAVL

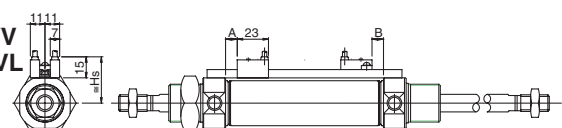

C85 Auto Switch Mounting Height

(mm)

Bore	D-C7□/C80 D-H7□ D-H7□W D-H7BAL D-H7NF	D-C73C D-C80C	D-A7□ D-A80	D-A7□H/A80H D-F7□/J79 D-F7□W/J79W D-F7BAL D-F79F	D-A73C D-A80C	D-H7C	D-A79W	D-J79C	D-F7□V D-F7□WV D-F7BAVL
	Hs	Hs	Hs	Hs	Hs	Hs	Hs	Hs	Hs
8	16	18.5	18	19	25	19	—	23.5	21.5
10	17	19.5	18	19	25	20	—	23.5	21.5
12	18.5	21	19.5	20.5	26.5	21	—	25	23
16	20.5	23	19.5	20.5	26.5	23	22	25	23
20	22.5	25	22.5	23.5	29.5	25	25	29	26
25	25	27.5	25.5	26.5	32.5	27.5	28	32	29

• Aim at this number.

ISO Cylinder: Standard/Non-rotating Type Single Acting, Spring Return/Extended

Series C85

ø8, ø10, ø12, ø16, ø20, ø25

How to Order

Single acting,
Spring return/
Spring extended

C D 85 K N 16 40 S B

Built-in magnet

Nil	None
D	Built-in magnet

Type

Nil	Standard
K	Non-rotating rod (Rubber cushion only)

Mounting style

Symbol	Mounting
N	Basic integrated clevis
E	Double end
F	Front nose
Y*	Front nose in line port

* Except single acting spring extended type.

Auto switch mounting style

A	Rail mounting
B	Band mounting

Applicable auto switches and bands are shown on page 6-11-44. Please order auto switches and bands separately.

Option

R	Stainless steel piston rod, rod end nut and mounting nut
R2	Stainless steel piston rod and rod end nut

Bore size

Stroke

Bore size (mm)	Standard stroke (mm)*	Max. stroke
8*	10, 25, 40, 50	50
10		
12		
16	10, 25, 40, 50, 80, 100, 125, 150	150
20		
25		

* Other strokes available on request.

Action

S	Single acting, Spring return
T	Single acting, Spring extended

CJ1

CJP

CJ2

CM2

CG1

MB

MB1

CA2

CS1

C76

C85

C95

CP95

NCM

NCA

D-

-X

20-

Data

Mounting Bracket Part No.

Bore size (mm)		8	10	12	16	20	25
Mounting bracket	Foot (1 pc.)	C85L10A		C85L16A		C85L25A	
	Foot (2 pcs. with mounting nut 1 pc.)	C85L10B		C85L16B		C85L25B	
	Flange	C85F10		C85F16		C85F25	
	Trunnion	C85T10		C85T16		C85T25	
	Clevis	C85C10		C85C16		C85C25	
Accessory	Single knuckle joint	KJ4D		KJ6D		KJ8D	KJ10D
	Double knuckle joint	GKM4-8		GKM6-10		GKM8-16	GKM10-20
	Floating joint	JA10-4-070		JA15-6-100		JA20-8-125	JA30-10-125

Replacement Parts For Standard Cylinders

Bore size (mm)	Part no.	Note
20	C85-20PS	Every set includes: n°1 rod packing n°1 packing retaining washer n°1 retaining ring
25	C85-25PS	

For Non-rotating Cylinders ("K")

Bore size (mm)	Part no.	Note
20	C85K-20PS	Every set includes: n°1 rod packing n°1 packing retaining washer n°1 retaining ring
25	C85K-25PS	

Series C85



Spring return



Spring extended

Rubber cushion



Non-rotating

Specifications

Bore size (mm)		8	10	12	16	20	25
Piston rod dia. (mm)		4	4	6	6	8	10
Piston rod thread		M4 x 0.7	M4 x 0.7	M6 x 1	M6 x 1	M8 x 1.25	M10 x 1.25
Port size		M5 x 0.8	M5 x 0.8	M5 x 0.8	M5 x 0.8	G 1/8	G 1/8
Action		Single acting, Single rod, Spring return/extend					
Fluid		Air					
Proof pressure		1.5 MPa					
Max. operating pressure		1.0 MPa					
Min. operating pressure	Spring return	0.22 MPa	0.18 MPa		0.13 MPa	0.18 MPa	
	Spring extended					0.23 MPa	
Ambient and fluid temperature		-20 to 80°C (Built-in magnet type: -10 to 60°C)					
Cushion		Rubber cushion (Standard)					
Lubrication		Not required. Use turbine oil Class 1 ISO VG32, if lubricated.					
Piston speed		50 to 1500 mm/s					
Allowable kinetic energy		0.02 J	0.03 J	0.04 J	0.09 J	0.27 J	0.4 J
Non-rotating accuracy*		±1° 30'	±1° 30'	±1°	±1°	±0° 42'	±0° 42'
Stroke tolerance (mm)		0/+1				0/+1.4	

JIS Symbol
Standard

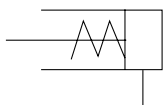

Spring return

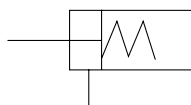

Spring extended

Non-rotating

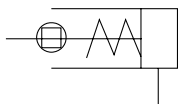

Spring return

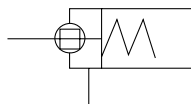

Spring extended

Spring Retracting Force (Standard, Non-rotating)

Spring Return

(N)

Bore size (mm)	Standard stroke (mm)	Spring force									
		10		25		50		100		150	
		Retract	Extended	Retract	Extended	Retract	Extended	Retract	Extended	Retract	Extended
8	10, 25, 50	4.41	4.02	4.41	3.43	4.41	2.45	—	—	—	—
10		6.28	5.69	6.28	4.90	6.28	3.53	—	—	—	—
12		7.16	6.57	7.16	5.79	7.16	4.41	—	—	—	—
16	10, 25, 50, 100, 150	13.2	12.1	13.2	10.3	13.2	7.45	13.2	7.45	13.2	7.45
20		21.6	18.6	21.6	16.7	21.6	11.8	39.2	9.81	39.2	9.81
25		27.5	25.3	27.5	22.1	27.5	16.7	47.1	13.7	47.1	15.7

Spring Extended

(N)

Bore size (mm)	Standard stroke (mm)	Spring force									
		10		25		50		100		150	
		Retract	Extend	Retract	Extend	Retract	Extend	Retract	Extend	Retract	Extend
8	10, 25, 50	5.30	3.92	5.30	3.14	5.30	2.65	—	—	—	—
10		5.98	4.81	5.98	4.02	5.98	3.53	—	—	—	—
12		6.57	5.59	6.57	4.90	6.57	4.51	—	—	—	—
16	10, 25, 50, 100, 150	14.7	11.3	14.7	9.22	14.7	7.85	14.7	7.85	14.7	7.85
20		39.2	33.0	39.2	23.5	39.2	9.81	39.2	9.81	39.2	9.81
25		47.1	40.4	47.1	30.4	47.1	13.7	47.1	13.7	47.1	15.7

ISO Cylinder: Standard/Non-rotating Type Single Acting, Spring Return/Extended **Series C85**

Auto Switch Mounting, Minimum Possible Cylinder Stroke

Band Mounting Style

Bore size: ø8, ø10, ø12, ø16

(mm)

Auto switch model	No. of auto switches				1 pc.
	3 pcs.		2 pcs.		
	Different sides	Same side	Different sides	Same side	
D-C7□ D-C80	55	90	15	50	10
D-C73C D-C80C D-H7C	65	105	15	65	10
D-H7□ D-H7□W D-H7BAL D-H7NF	60	105	15	60	10

Rail Mounting Style

Bore size: ø8, ø10, ø12, ø16

(mm)

Auto switch model	No. of auto switches		1 pc.
	3 pcs.	2 pcs.	
	D-A7□/A80 D-A73C/A80C	35	
D-A7□H D-A80H	45	10	5
D-A79W *	40	15	10
D-F7□ D-J79	45	5	5
D-F7□V D-J79C	30	5	5
D-F7□W D-J79W D-F7BAL D-F79F	55	15	10
D-F7□WV D-F7BAVL	40	15	10

* "D-A79W" cannot be mounted on bore size ø8, ø10, ø12 cylinder.

Band Mounting Style

Bore size: ø20, ø25

(mm)

Auto switch model	No. of auto switches				1 pc.
	2 pcs.		n pcs.		
	Different sides	Same side	Different sides	Same side	
D-C7□ D-C80	15	50	$15 + 45\left(\frac{n-2}{2}\right)$ (n = 2, 4...)	$50 + 45(n-2)$	10
D-C73C D-C80C D-H7C	15	65	$15 + 50\left(\frac{n-2}{2}\right)$ (n = 2, 4...)	$65 + 50(n-2)$	10
D-H7□ D-H7□W D-H7BAL D-H7NF	15	60	$15 + 45\left(\frac{n-2}{2}\right)$ (n = 2, 4...)	$60 + 55(n-2)$	10

Rail Mounting Style

Bore size: ø20, ø25

(mm)

Auto switch model	No. of auto switches		1 pc.
	2 pcs.	n pcs.	
	D-A7□/A80 D-A7□H/A80H D-A73C/A80C D-F7□ D-F7□V D-J79 D-J79C	10	
D-A79W D-F7□W D-J79W D-F7BAL D-F79F D-F7□WV D-F7BAVL	15	$15 + 35\left(\frac{n-2}{2}\right)$ (n = 2, 4...)	10

CJ1

CJP

CJ2

CM2

CG1

MB

MB1

CA2

CS1

C76

C85

C95

CP95

NCM

NCA

D-

-X

20-

Data

Series C85

Construction

[First angle projection]

Single acting, Single rod

Spring return: C□85□8 to 16-□S (Disassembly is not possible.)

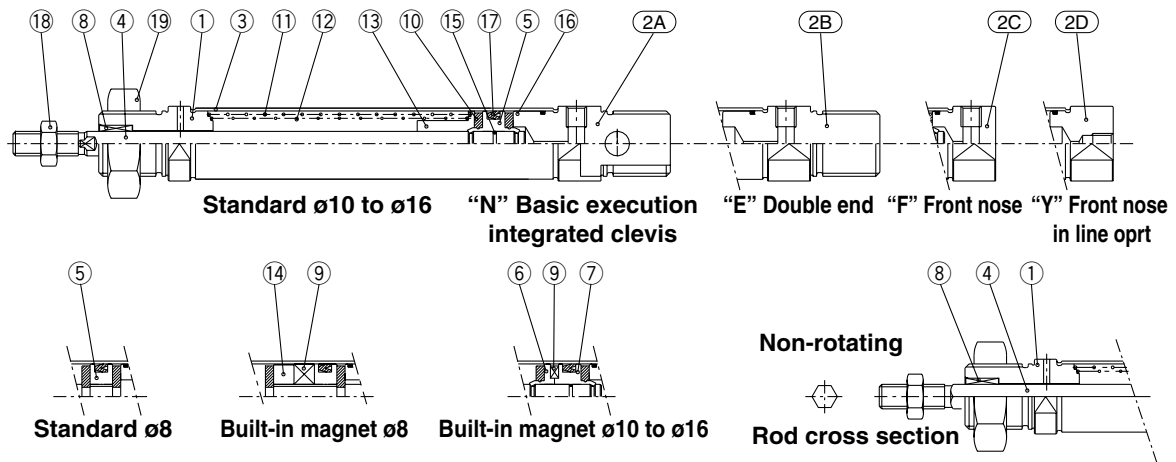

Component Parts

No.	Description	Material	Qty.	Note
①	Rod cover	Aluminum alloy	1	White anodized
②A	Head cover N	Aluminum alloy	1	White anodized
②B	Head cover E	Aluminum alloy	1	White anodized
②C	Head cover F	Aluminum alloy	1	White anodized
②D	Head cover Y	Aluminum alloy	1	White anodized
③	Cylinder tube	Stainless steel	1	
④	Piston rod	Stainless steel	1	
⑤	Piston	Brass	1	
⑥	Piston A	Brass	1	(Switch type only)
⑦	Piston B	Brass	1	(Switch type only)
⑧	Bush	Sintered bronze	1	

No.	Description	Material	Qty.	Note
⑨	Magnet	Magnet	1	(Switch type only)
⑩	Bumper	Urethane	2	
⑪	Return spring A	Piano wire	1	
⑫	Return spring B	Piano wire	1	
⑬	Spring guide	Brass	1	
⑭	Spacer	Brass	1	
⑮	Piston gasket	NBR	1	(2 for switch type)
⑯	Tube gasket	NBR	1	
⑰	Piston seal	NBR	1	
⑱	Rod end nut	Carbon steel	1	Nickel plating
⑲	Mounting nut	Carbon steel	1	Nickel plating

Spring Extended: C□85□8 to 16-□T (Disassembly is not possible.)

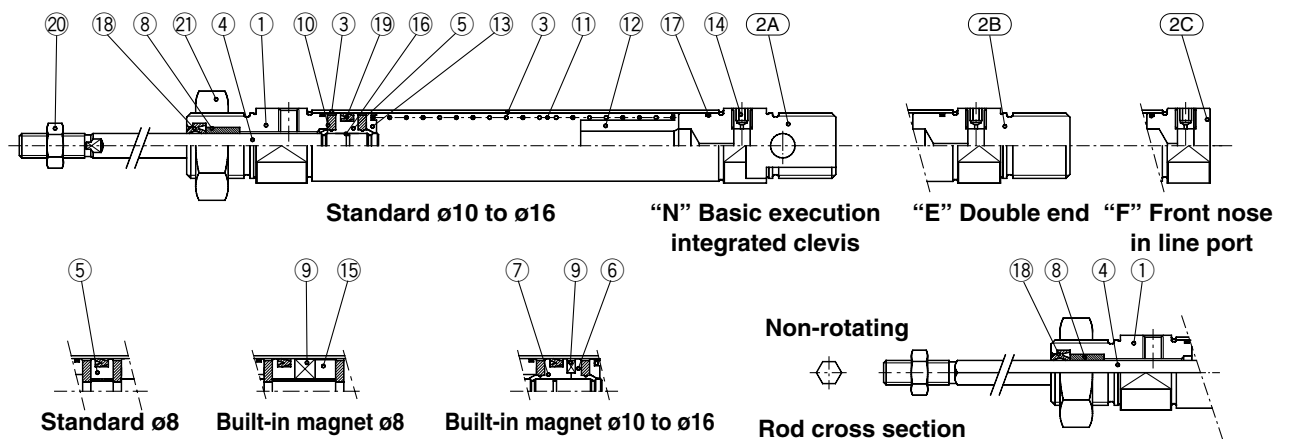

Component Parts

No.	Description	Material	Qty.	Note
①	Rod cover	Aluminum alloy	1	White anodized
②A	Head cover N	Aluminum alloy	1	White anodized
②B	Head cover E	Aluminum alloy	1	White anodized
②C	Head cover F	Aluminum alloy	1	White anodized
③	Cylinder tube	Stainless steel	1	
④	Piston rod	Stainless steel	1	
⑤	Piston	Brass	1	
⑥	Piston A	Brass	1	(Switch type only)
⑦	Piston B	Brass	1	(Switch type only)
⑧	Bush	Sintered bronze	1	
⑨	Magnet	Magnet	1	(Switch type only)

No.	Description	Material	Qty.	Note
⑩	Bumper	Urethane	2	
⑪	Return spring C	Piano wire	1	
⑫	Spring guide	Brass	1	
⑬	Spring seat	Brass	1	
⑭	Plug	Steel	1	
⑮	Spacer	Brass	1	
⑯	Piston gasket	NBR	1	(2 for switch type)
⑰	Tube gasket	NBR	1	
⑱	Rod seal	NBR	1	
⑲	Piston seal	NBR	1	
⑳	Rod end nut	Carbon steel	1	Nickel plating
㉑	Mounting nut	Carbon steel	1	Nickel plating

ISO Cylinder: Standard/Non-rotating Type Single Acting, Spring Return/Extended Series C85

Construction

[First angle projection]

Single acting, Single rod
Spring return: C□85□20/25-□S

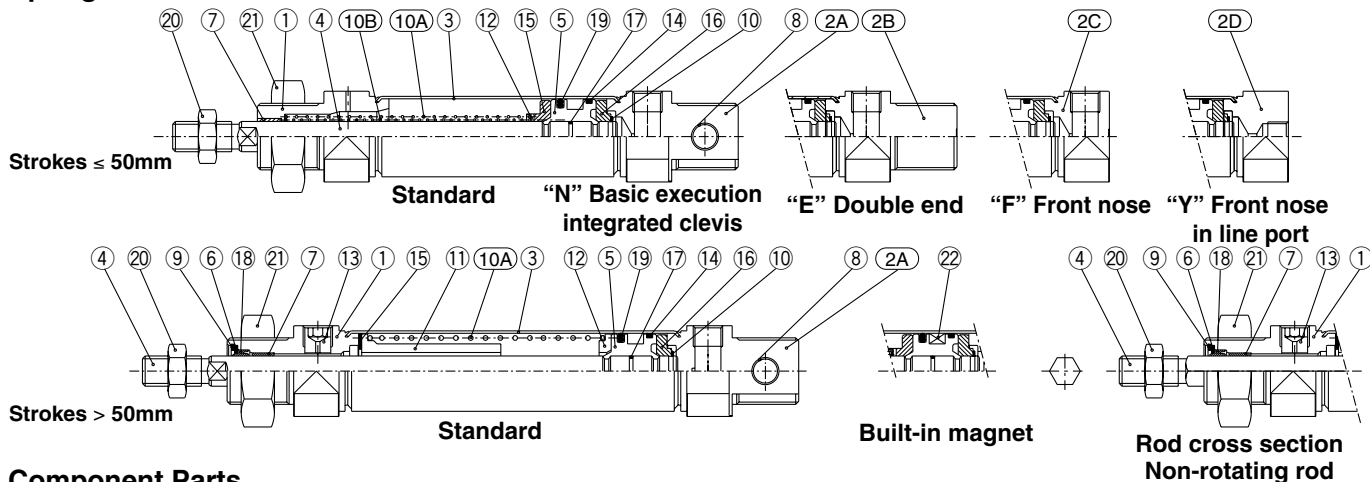

Component Parts

No.	Description	Material	Qty.	Note
①	Rod cover	Aluminum alloy	1	White anodized
②A	Head cover N	Aluminum alloy	1	White anodized
②B	Head cover E	Aluminum alloy	1	White anodized
②C	Head cover F	Aluminum alloy	1	White anodized
②D	Head cover Y	Aluminum alloy	1	White anodized
③	Cylinder tube	Stainless steel	1	
④	Piston rod	Carbon steel	1	Hard chrome plated
⑤	Piston	Aluminum alloy	1	Chromate
⑥	Plain washer	Stainless steel	1	
⑦	Bush	Sintered bronze	1	
⑧	Bush	Sintered bronze	1	
⑨	Retaining ring	Stainless steel	1	Nickel plating
⑩	Retaining ring	Stainless steel	1	
⑩A	Return spring A	Piano wire	1	Zinc chromated

No.	Description	Material	Qty.	Note
⑩B	Return spring B	Piano wire	1	Zinc chromated
⑪	Spring guide	Aluminum alloy	1	
⑫	Spring holder	Aluminum alloy	1	
⑬	Set screw	Carbon steel	1	
⑭	Wear ring	Resin	1	
⑮	Bumper A	Urethane	1	
⑯	Bumper B	Urethane	1	
⑰	Piston gasket	NBR	1	
⑱	Rod seal	NBR	1	
⑲	Piston seal	NBR	1	
⑳	Rod end nut	Carbon steel	1	Nickel plating
㉑	Mounting nut	Carbon steel	1	Nickel plating
㉒	Magnet	Magnet	1	(Switch type only)

Spring extended: C□85□20/25-□T

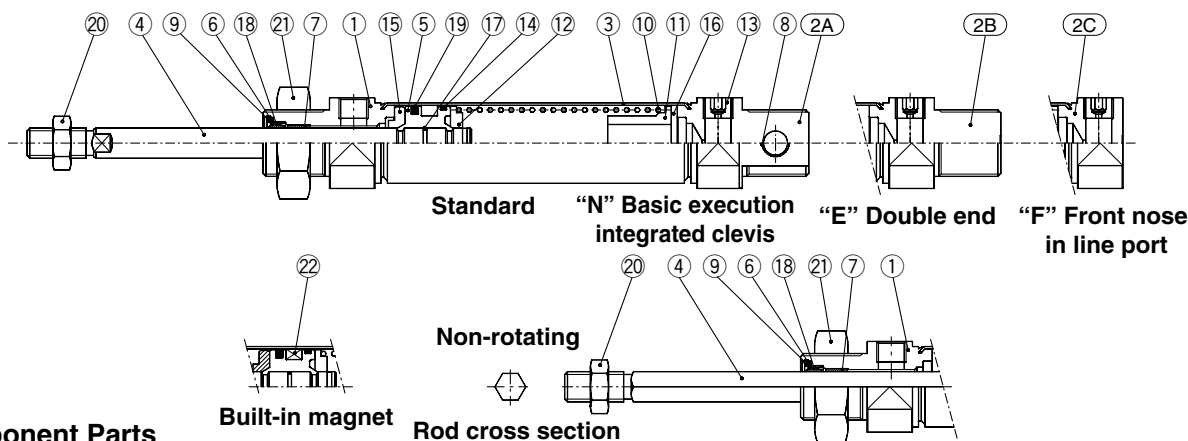

Component Parts

No.	Description	Material	Qty.	Note
①	Rod cover	Aluminum alloy	1	White anodized
②A	Head cover N	Aluminum alloy	1	White anodized
②B	Head cover E	Aluminum alloy	1	White anodized
②C	Head cover F	Aluminum alloy	1	White anodized
③	Cylinder tube	Stainless steel	1	
④	Piston rod	Carbon steel	1	Hard chrome plated
⑤	Piston	Aluminum alloy	1	Chromate
⑥	Plain washer	Stainless steel	1	
⑦	Bush	Sintered bronze	1	
⑧	Bush	Sintered bronze	1	
⑨	Retaining ring	Carbon steel	1	Nickel plating
⑩	Return spring	Piano wire	1	Zinc chromated

No.	Description	Material	Qty.	Note
⑪	Spring guide	Aluminum alloy	1	
⑫	Spring guide	Aluminum alloy	1	
⑬	Set screw	Carbon steel	1	
⑭	Wear ring	Resin	1	
⑮	Bumper A	Urethane	1	
⑯	Bumper B	Urethane	1	
⑰	Piston gasket	NBR	1	
⑱	Rod seal	NBR	1	
⑲	Piston seal	NBR	1	
⑳	Rod end nut	Carbon steel	1	Nickel plating
㉑	Mounting nut	Carbon steel	1	Nickel plating
㉒	Magnet	Magnet	1	(Switch type only)

- CJ1
- CJP
- CJ2
- CM2
- CG1
- MB
- MB1
- CA2
- CS1
- C76
- C85
- C95
- CP95
- NCM
- NCA
- D-
- X
- 20-
- Data

Series C85

Dimensions

[First angle projection]

Single acting, Spring return

C□85_E Bore-Stroke S-□

Without magnet, Built-in magnet

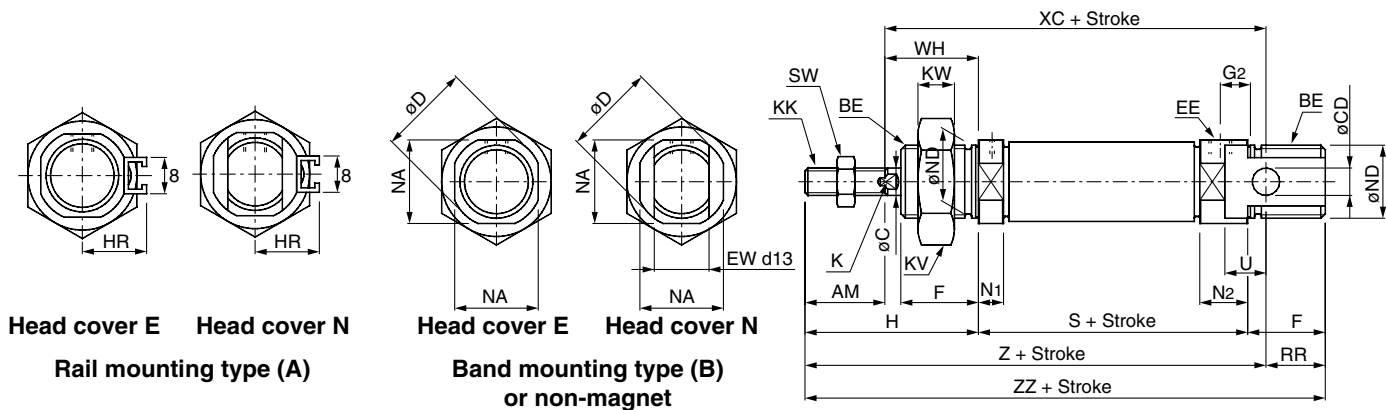

C□85KN, C□85KE
Non-rotating (Piston rod)

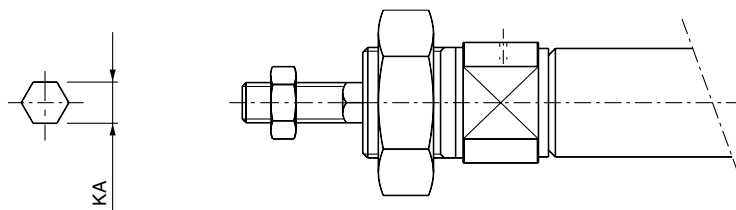

Rod cross section

Bore	AM	BE	øC	øCD H9	øD	EE	EW	F	G ₂	H	HR	K	KA	KK	KV	KW	N ₁	N ₂	NA	øND h8	RR	SW	U	WH
8	12	M12 x 1.25	4	4	16.7	M5 x 0.8	8	12	5	28	10	—	4.2	M4 x 0.7	19	6	5.5	9.5	15	12	10	7	6	16
10	12	M12 x 1.25	4	4	16.7	M5 x 0.8	8	12	5	28	10.5	—	4.2	M4 x 0.7	19	6	5.5	9.5	15	12	10	7	6	16
12	16	M16 x 1.5	6	6	19.7	M5 x 0.8	12	17	6	38	14	5	6.2	M6 x 1	24	8	5.5	10.5	18.3	16	14	10	9	22
16	16	M16 x 1.5	6	6	19.7	M5 x 0.8	12	17	6	38	14	5	6.2	M6 x 1	24	8	5.5	10.5	18.3	16	13	10	9	22
20	20	M22 x 1.5	8	8	28	G 1/8	16	20	8	44	17	6	8.2	M8 x 1.25	32	11	15	15	24	22	11	13	12	24
25	22	M22 x 1.5	10		33.5	G 1/8	16	22	8	50	20	8	10.2	M10 x 1.25	32	11	15	15	30	22	11	17	12	28

(mm)

Bore	S			XC			Z			ZZ		
	1 to 50	51 to 100	101 to 150	1 to 50	51 to 100	101 to 150	1 to 50	51 to 100	101 to 150	1 to 50	51 to 100	101 to 150
8	46{52}{56{62}}	—	—	64{70}{74{80}}	—	—	76{82}{86{92}}	—	—	86{92}{96{102}}	—	—
10	46{50}{56{60}}	—	—	64{68}{74{78}}	—	—	76{80}{86{90}}	—	—	86{90}{96{100}}	—	—
12	50{53.5}{60{63.5}}	—	—	75{78.5}{85{88.5}}	—	—	91{94.5}{101{104.5}}	—	—	105{108.5}{115{118.5}}	—	—
16	56{59.5}{66{69.5}}	71.5{75}{92{95.5}}	87{90.5}{118{121.5}}	82{85.5}{92{95.5}}	97.5{101}{118{121.5}}	113{116.5}{144{147.5}}	98{101.5}{108{111.5}}	113.5{117}{134{137.5}}	129{132.5}{160{163.5}}	111{114.5}{121{124.5}}	126.5{130}{147{150.5}}	142{145.5}{173{176.5}}
20	62{87}	112	137	95{120}	145	170	115{140}	165	190	126{151}	176	201
25	65{88.5}	113.5	138.5	104{127.5}	152.5	177.5	126{149.5}	174.5	199.5	137{160.5}	185.5	210.5

(): In the case of auto switch style. { }: In the case of non-rotating rod.

ISO Cylinder: Standard/Non-rotating Type Single Acting, Spring Return/Extended Series C85

Dimensions with Mounting Bracket

[First angle projection]

Single acting, Spring return

Rod foot, Rod and head foot: C85L10^A, C85L16^A, C85L25^A

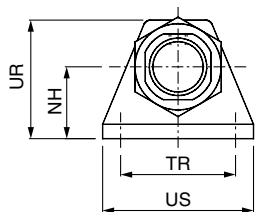

Head cover E

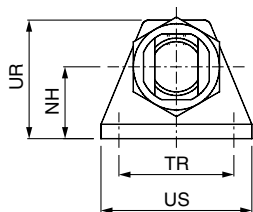

Head cover N

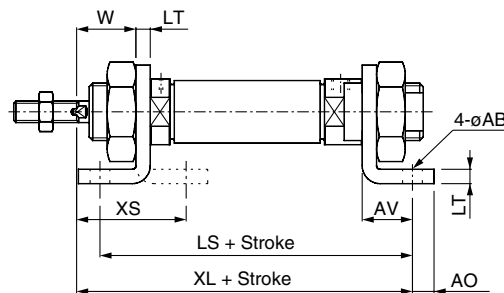

Rod flange, Head flange: C85F10, C85F16, C85F25

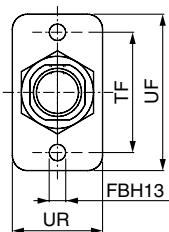

Head cover E

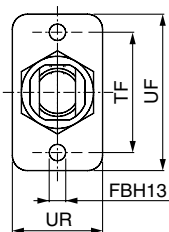

Head cover N

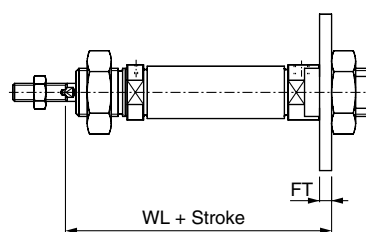
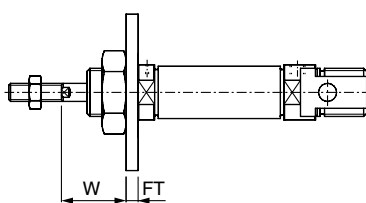

Rod trunnion, Head trunnion: C85T10, C85T16, C85T25

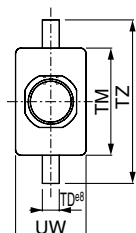

Head cover E

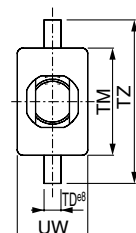

Head cover N

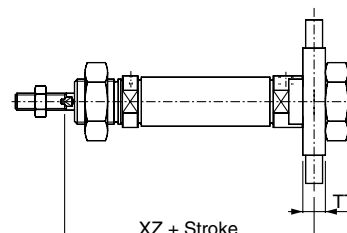
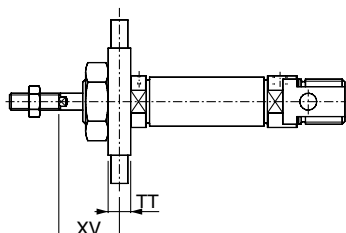

Clevis: C85C10, C85C16, C85C25

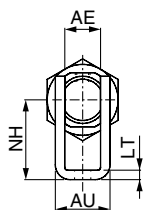

Head cover N

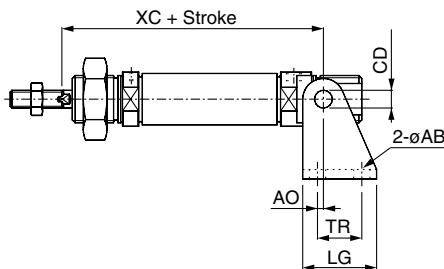

(mm)

Bore	Rod foot, Rod and head foot														Rod flange, Head flange										
	AO	US	φAB	LT	NH	LS			XL			TR JS14	XS	AV	UR	W	UR	FBH13	FT	TF	UF	W	WL		
						1 to 50	51 to 100	101 to 150	1 to 50	51 to 100	101 to 150												1 to 50	51 to 100	101 to 150
8	5	35	4.5	3.2	16	68(74) {78(84)}	—	—	73(79) {83(89)}	—	—	25	23.8	11	26	12.8	22	4.5	3.2	30	40	12.8	65.2(71.2) {75.2(81.2)}	—	—
10	5	35	4.5	3.2	16	68(72) {78(82)}	—	—	73(77) {83(87)}	—	—	25	23.8	11	26	12.8	22	4.5	3.2	30	40	12.8	65.2(69.2) {75.2(79.2)}	—	—
12	6	42	5.5	4	20	78(81.5) {88(91.5)}	—	—	86(89.5) {96(99.5)}	—	—	32	32	14	33	18	30	5.5	4	40	52	18	76(79.5) {86(89.5)}	—	—
16	6	42	5.5	4	20	84(87.5) {94(97.5)}	99.5(103) {120(123.5)}	115(118.5) {146(149.5)}	92(95.5) {102(105.5)}	107.5(111) {128(131.5)}	123(126.5) {154(157.5)}	32	32	14	33	18	30	5.5	4	40	52	18	82(85.5) {92(95.5)}	97.5(101) {118(121.5)}	113(116.5) {144(147.5)}
20	8	54	6.6	5	25	96{121}	146	171	103{128}	153	178	40	36	17	42	19	40	6.6	5	50	66	19	91{116}	141	166
25	8	54	6.6	5	25	96{122.5}	147.5	172.5	110{133.5}	158.5	183.5	40	40	17	42	23	40	6.6	5	50	66	23	98{121.5}	146.5	171.5

Bore	Rod trunnion, Head trunion										Clevis										
	TT	UW	TD e8	TM	TZ	XV	XZ			φCD H9	AE	φAB	AO	AU	TR	LG	NH	LT	XC		
							1 to 50	51 to 100	101 to 150										1 to 50	51 to 100	101 to 150
8	6	20	4	26	38	13	65(71) {75(81)}	—	—	4	8.1	4.5	1.5	13.1	12.5	20	24	2.5	64(70) {74(80)}	—	—
10	6	20	4	26	38	13	65(69) {75(79)}	—	—	4	8.1	4.5	1.5	13.1	12.5	20	24	2.5	64(68) {74(78)}	—	—
12	8	25	6	38	58	18	76(79.5) {86(89.5)}	—	—	6	12.1	5.5	2	18.5	15	25	27	3.2	75(78.5) {85(88.5)}	—	—
16	8	25	6	38	58	18	82(85.5) {92(95.5)}	97.5(101) {118(121.5)}	113(116.5) {144(147.5)}	6	12.1	5.5	2	18.5	15	25	27	3.2	82(88.5) {92(95.5)}	97.5(101) {118(121.5)}	113(116.5) {144(147.5)}
20	8	32	6	46	66	20	90{115}	140	165	8	16.1	6.6	4	24.1	20	32	30	4	95{120}	145	170
25	8	32	6	46	66	24	97{120.5}	145.5	170.5		16.1	6.6	4	24.1	20	32	30	4	104{127.5}	152.5	177.5

() : In the case of auto switch style. { } : In the case of non-rotating rod.

- CJ1
- CJP
- CJ2
- CM2
- CG1
- MB
- MB1
- CA2
- CS1
- C76
- C85**
- C95
- CP95
- NCM
- NCA
- D-
- X
- 20-
- Data

Series C85

Dimensions

[First angle projection]

Single acting, Spring return

C□85^F□Bore-Stroke S-□

Without magnet, Built-in magnet

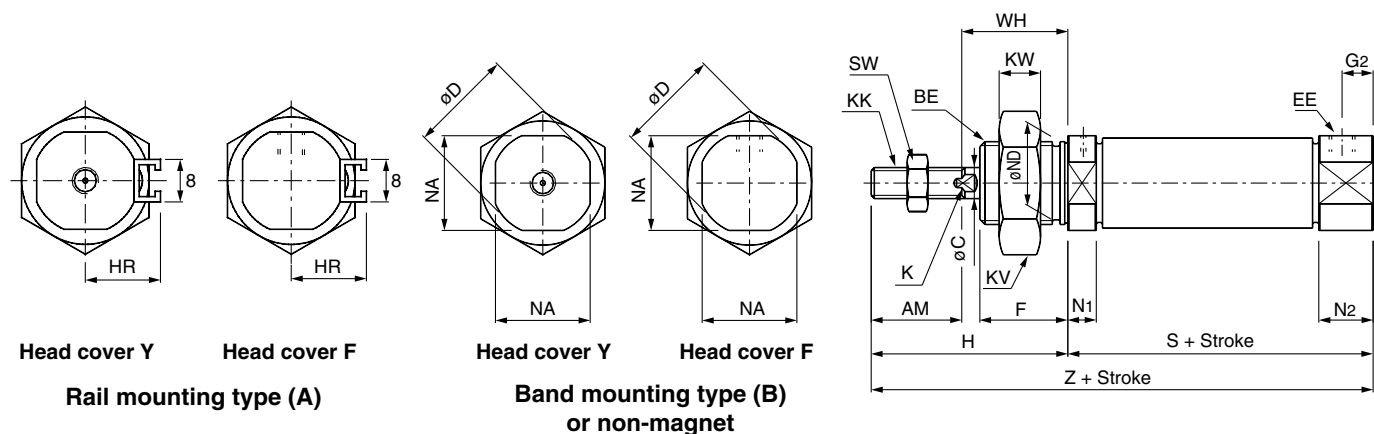

C□85KF, C□85KY
Non-rotating (Piston rod)

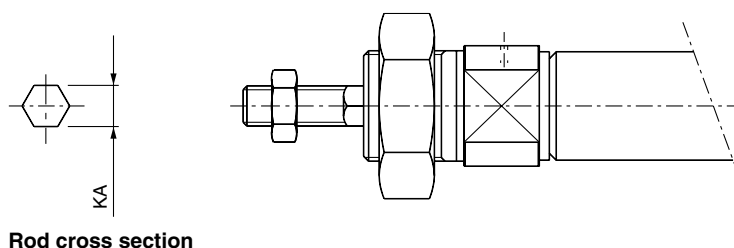

Rod cross section

Bore	AM	BE	øC	øD	EE	F	G2	H	HR	K	KA	KK	KV	KW	N1	N2	NA	øND h8	SW	WH
8	12	M12 x 1.25	4	16.7	M5 x 0.8	12	5	28	10	—	4.2	M4 x 0.7	19	6	5.5	9.5	15	12	7	16
10	12	M12 x 1.25	4	16.7	M5 x 0.8	12	5	28	10.5	—	4.2	M4 x 0.7	19	6	5.5	9.5	15	12	7	16
12	16	M16 x 1.5	6	19.7	M5 x 0.8	17	6	38	14	5	6.2	M6 x 1	24	8	5.5	10.5	18.3	16	10	22
16	16	M16 x 1.5	6	19.7	M5 x 0.8	17	6	38	14	5	6.2	M6 x 1	24	8	5.5	10.5	18.3	16	10	22
20	20	M22 x 1.5	8	28	G 1/8	20	8	44	17	6	8.2	M8 x 1.25	32	11	15	15	24	22	13	24
25	22	M22 x 1.5	10	33.5	G 1/8	22	8	50	20	8	10.2	M10 x 1.25	32	11	15	15	30	22	17	28

Bore	S			Z		
	1 to 50	51 to 100	101 to 150	1 to 50	51 to 100	101 to 150
8	46(52){56(62)}	—	—	74(80){84(90)}	—	—
10	46(50){56(60)}	—	—	74(78){84(88)}	—	—
12	50(53.5){60(63.5)}	—	—	88(91.5){98(101.5)}	—	—
16	50(53.5){60(63.5)}	65.5(69){86(89.5)}	81(84.5){112(115.5)}	88(91.5){98(101.5)}	103.5(107){124(127.5)}	119(122.5){150(153.5)}
20	62{87}	112	137	106{131}	156	181
25	65{88.5}	113.5	138.5	115{138.5}	163.5	188.5

(): In the case of auto switch type. { }: In the case of non-rotating.

ISO Cylinder: Standard/Non-rotating Type Single Acting, Spring Return/Extended **Series C85**

Dimensions with Mounting Bracket

[First angle projection]

Single acting, Spring return
Rod foot: C85L10A, C85L16A, C85L25A

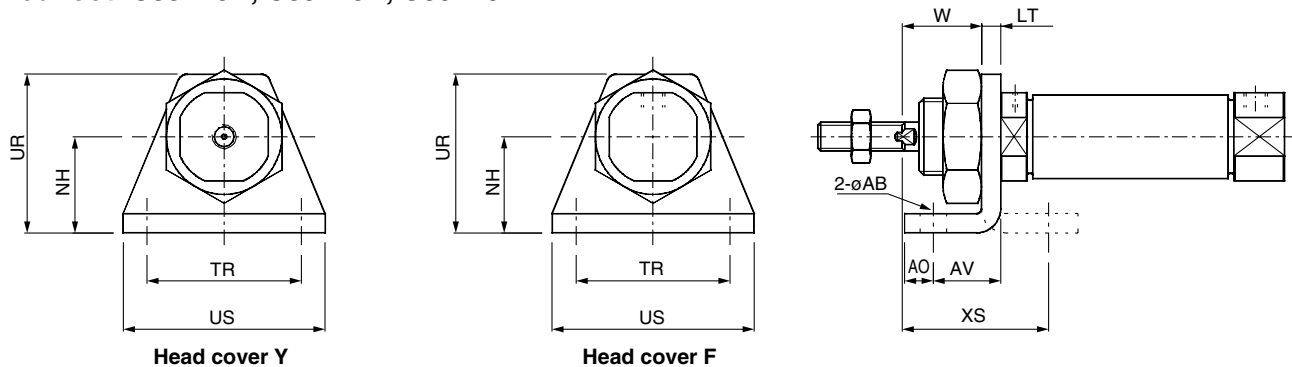

Rod flange: C85F10, C85F16, C85F25

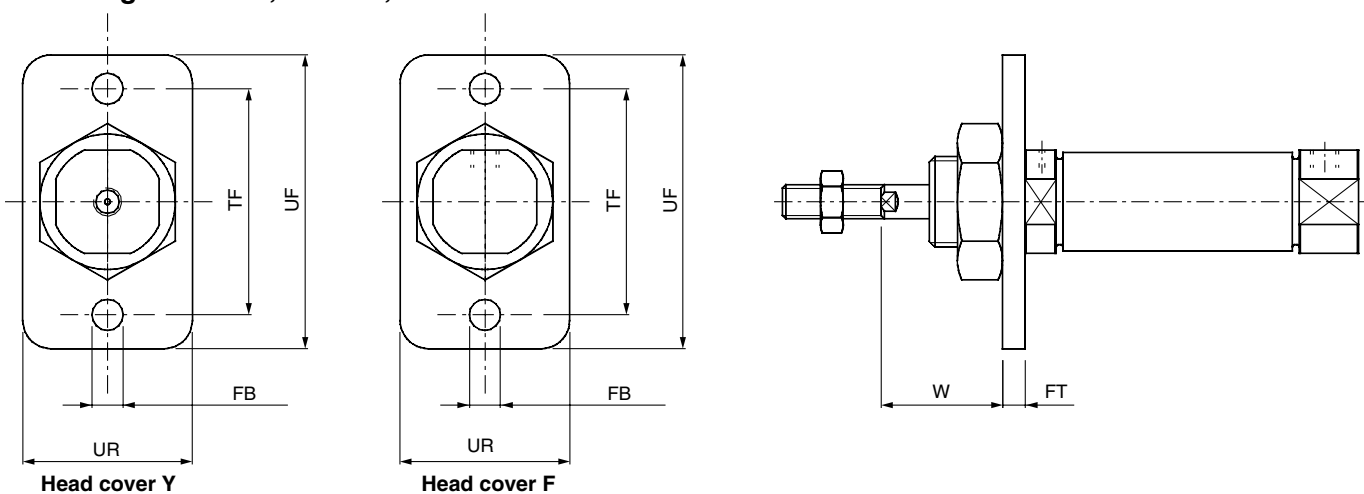

Rod trunnion: C85T10, C85T16, C85T25

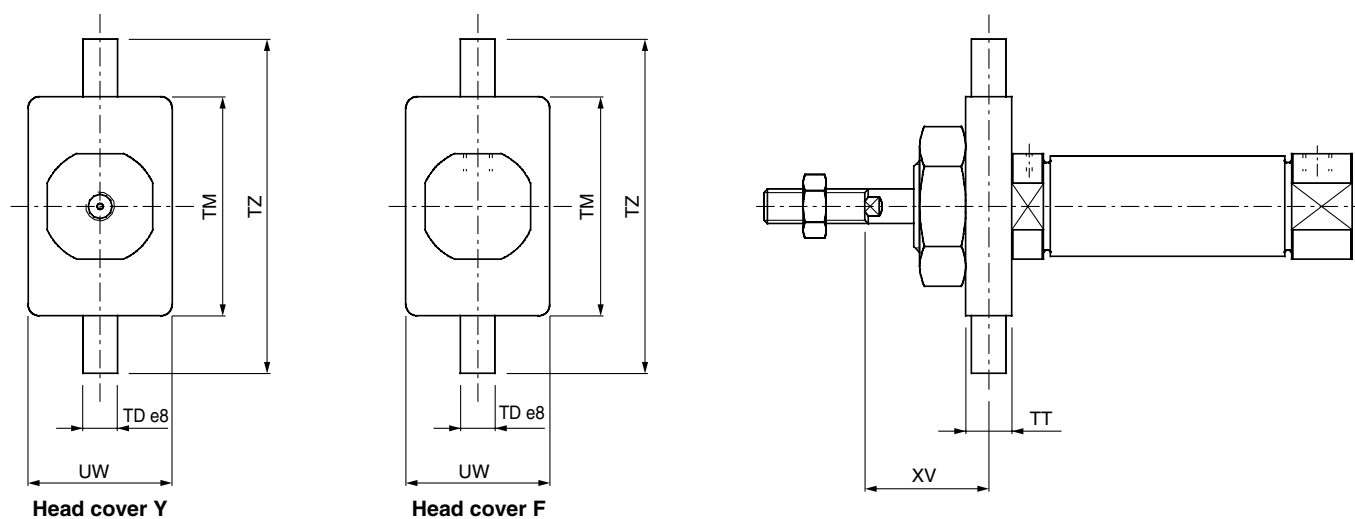

- CJ1
- CJP
- CJ2
- CM2
- CG1
- MB
- MB1
- CA2
- CS1
- C85**
- C95
- CP95
- NCM
- NCA
- D-
- X
- 20-
- Data

Bore	Rod foot										Rod flange					Rod trunnion						
	AO	US	øAB	LT	NH	TR JS14	XS	AV	UR	W	UR	FBH13	FT	TF	UF	W	TT	UW	TD e8	TM	TZ	XV
8	5	35	4.5	3.2	16	25	23.8	11	26	12.8	22	4.5	3.2	30	40	12.8	6	20	4	26	38	13
10	5	35	4.5	3.2	16	25	23.8	11	26	12.8	22	4.5	3.2	30	40	12.8	6	20	4	26	38	13
12	6	42	5.5	4	20	32	32	14	33	18	30	5.5	4	40	52	18	8	25	6	38	58	18
16	6	42	5.5	4	20	32	32	14	33	18	30	5.5	4	40	52	18	8	25	6	38	58	18
20	8	54	6.6	5	25	40	36	17	42	19	40	6.6	5	50	66	19	8	32	6	46	66	20
25	8	54	6.6	5	25	40	40	17	42	23	40	6.6	5	50	66	23	8	32	6	46	66	24

Series C85

Dimensions

[First angle projection]

Single acting, Spring return

C□85^N_E Bore—Stroke T—□

Without magnet, Built-in magnet

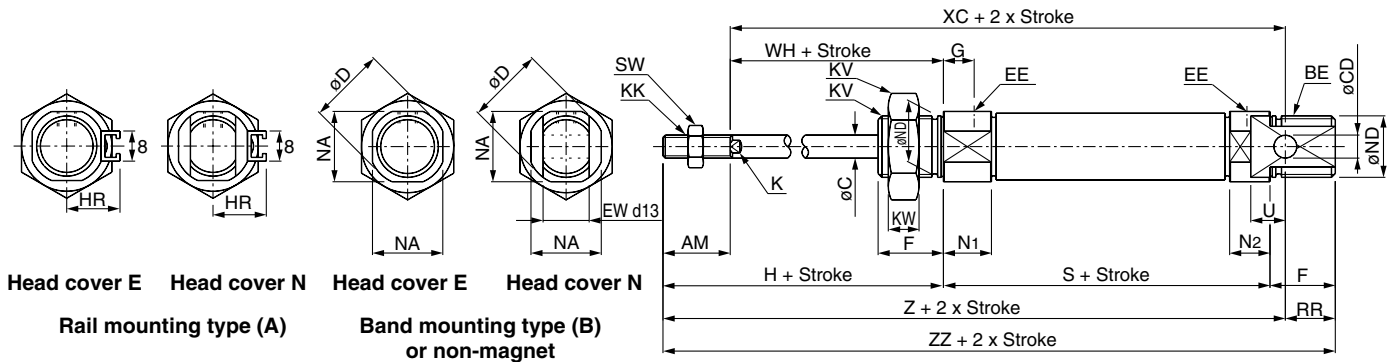

C□85KN/E

Non-rotating (Piston rod)

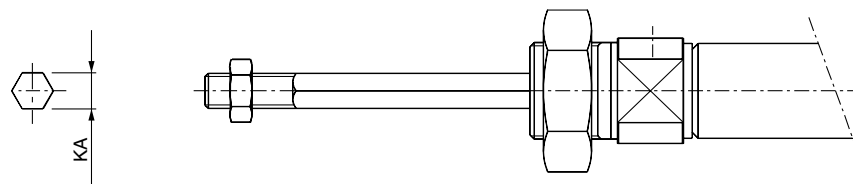

Rod cross section

Bore	AM	BE	øC	øCD H9	øD	EE	EW	F	G	H	HR	K	KA	KK	KV	KW	N ₁	N ₂	NA	øND h8	RR	SW	U	WH
8	12	M12 x 1.25	4	4	16.7	M5 x 0.8	8	12	7	28	10	—	4.2	M4 x 0.7	19	6	11.5	9.5	15	12	10	7	6	16
10	12	M12 x 1.25	4	4	16.7	M5 x 0.8	8	12	7	28	10.5	—	4.2	M4 x 0.7	19	6	11.5	9.5	15	12	10	7	6	16
12	16	M16 x 1.5	6	6	19.7	M5 x 0.8	12	17	8	38	14	5	6.2	M6 x 1	24	8	12.5	10.5	18.3	16	14	10	9	22
16	16	M16 x 1.5	6	6	19.7	M5 x 0.8	12	17	8	38	14	5	6.2	M6 x 1	24	8	12.5	10.5	18.3	16	13	10	9	22
20	20	M22 x 1.5	8	8	28	G 1/8	16	20	8	44	17	6	8.2	M8 x 1.25	32	11	15	15	24	22	11	13	12	24
25	22	M22 x 1.5	10		33.5	G 1/8	16	22	8	50	20	8	10.2	M10 x 1.25	32	11	15	15	30	22	11	17	12	28

(mm)

Bore	S			Z			XC			ZZ		
	1 to 50	51 to 100	101 to 150	1 to 50	51 to 100	101 to 150	1 to 50	51 to 100	101 to 150	1 to 50	51 to 100	101 to 150
8	64.5(70.5)	—	—	94.5(100.5)	—	—	82.5(88.5)	—	—	104.5(110.5)	—	—
10	64.5(68.5)	—	—	94.5(98.5)	—	—	82.5(86.5)	—	—	104.5(108.5)	—	—
12	70(73.5)	—	—	111(114.5)	—	—	95(98.5)	—	—	125(128.5)	—	—
16	75(78.5)	101(104.5)	127(130.5)	117(120.5)	143(146.5)	169(172.5)	101(104.5)	127(130.5)	153(156.5)	130(133.5)	156(159.5)	182(185.5)
20	87	112	137	140	165	190	120	145	170	151	176	201
25	88.5	113.5	138.5	149.5	174.5	199.5	127.5	152.5	177.5	160.5	185.5	210.5

(): In the case of auto switch style.

ISO Cylinder: Standard/Non-rotating Type Single Acting, Spring Return/Extended **Series C85**

Dimensions with Mounting Bracket

[First angle projection]

Single acting, Spring extended

C□85N, C□85E

Rod foot, Rod and head foot: C85L10^A_B, C85L16^A_B, C85L25^A_B

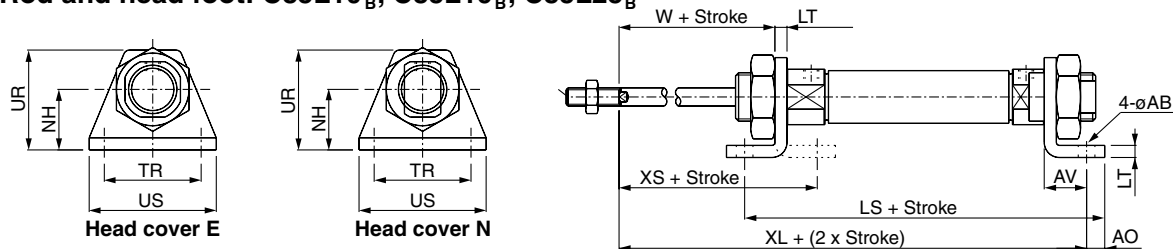

C□85N, C□85E

Rod flange, Head flange: C85F10, C85F16, C85F25

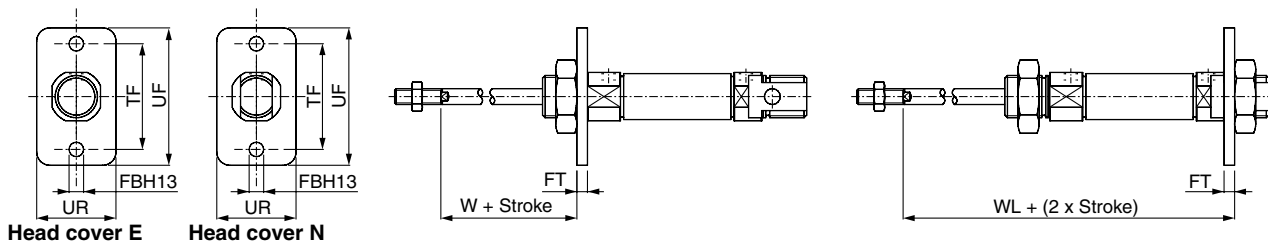

C□85N, C□85E

Rod trunnion, Head trunnion: C85T10, C85T16, C85T25

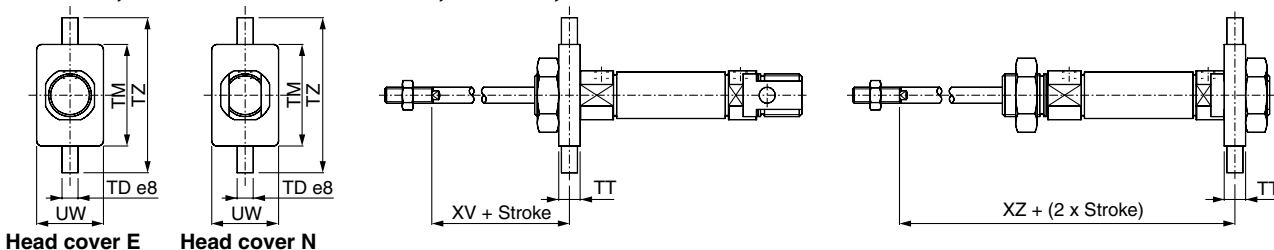

C□85N

Clevis: C85C10, C85C16, C85C25

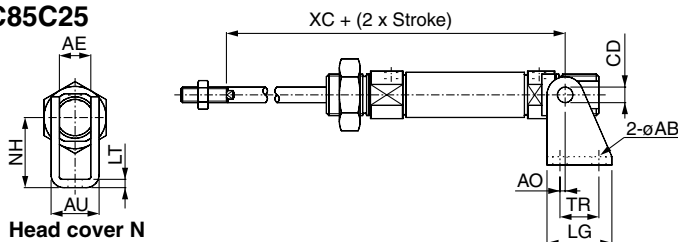

(mm)

Bore	Front foot, Rod and head foot														Rod flange, Head flange										
	AO	US	øAB	LT	NH	LS			XL			TR JS14	XS	AV	UR	W	UR	FBH13	FT	TF	UF	W	WL		
						1 to 50	51 to 100	101 to 150	1 to 50	51 to 100	101 to 150												1 to 50	51 to 100	101 to 150
8	5	35	4.5	3.2	16	86.5(92.5)	—	—	91.5(97.5)	—	—	25	23.8	11	26	12.8	22	4.5	3.2	30	40	12.8	83.7(89.7)	—	—
10	5	35	4.5	3.2	16	86.5(90.5)	—	—	91.5(95.5)	—	—	25	23.8	11	26	12.8	22	4.5	3.2	30	40	12.8	83.7(87.7)	—	—
12	6	42	5.5	4	20	98(101.5)	—	—	106(109.5)	—	—	32	32	14	33	18	30	5.5	4	40	52	18	96(99.5)	—	—
16	6	42	5.5	4	20	103(106.5)	129(132.5)	155(158.5)	111(114.5)	137(140.5)	163(166.5)	32	32	14	33	18	30	5.5	4	40	52	18	101(104.5)	127(130.5)	153(156.5)
20	8	54	6.6	5	25	121	146	171	128	153	178	40	36	17	42	19	40	6.6	5	50	66	19	116	141	166
25	8	54	6.6	5	25	122.5	147.5	172.5	133.5	158.5	183.5	40	40	17	42	23	40	6.6	5	50	66	23	121.5	146.5	171.5

Bore	Rod trunnion, Head trunnion								Clevis												
	TT	UW	TD e8	TM	TZ	XV	XZ			øCD H9	AE	øAB	AO	AU	TR	LG	NH	LT	XC		
							1 to 50	51 to 100	101 to 150										1 to 50	51 to 100	101 to 150
8	6	20	4	26	38	13	83.5(89.5)	—	—	4	8.1	4.5	1.5	13.1	12.5	20	24	2.5	82.5(88.5)	—	—
10	6	20	4	26	38	13	83.5(87.5)	—	—	4	8.1	4.5	1.5	13.1	12.5	20	24	2.5	82.5(86.5)	—	—
12	8	25	6	38	58	18	96(99.5)	—	—	6	12.1	5.5	2	18.5	15	25	27	3.2	95(98.5)	—	—
16	8	25	6	38	58	18	101(104.5)	127(130.5)	153(156.5)	6	12.1	5.5	2	18.5	15	25	27	3.2	101(104.5)	127(130.5)	153(156.5)
20	8	32	6	46	66	20	115	140	165	8	16.1	6.6	4	24.1	20	32	30	4	120	145	170
25	8	32	6	46	66	24	120.5	145.5	170.5		16.1	6.6	4	24.1	20	32	30	4	127.5	152.5	177.5

() : In the case of auto switch style.

- CJ1
- CJP
- CJ2
- CM2
- CG1
- MB
- MB1
- CA2
- CS1
- C76
- C85**
- C95
- CP95
- NCM
- NCA
- D-
- X
- 20-
- Data

Series C85

Dimensions

[First angle projection]

Single acting, Spring extended

C□85F Bore Stroke T□

Without magnet, Built-in magnet

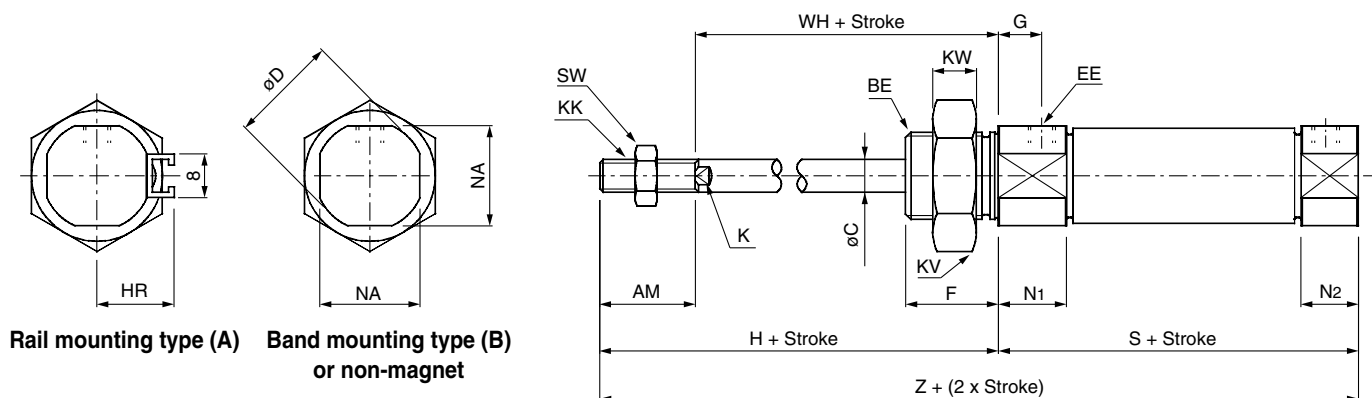

Rail mounting type (A) Band mounting type (B)
or non-magnet

C85KF, CD85KF
Non-rotating (Piston rod)

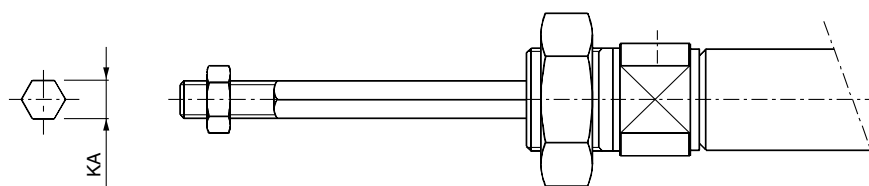

Rod cross section

Bore	AM	BE	øC	øD	EE	F	G	H	HR	K	KA	KK	KV	KW	N1	N2	NA	SW	WH
8	12	M12 x 1.25	4	16.7	M5 x 0.8	12	7	28	10	—	4.2	M4 x 0.7	19	6	11.5	9.5	15	7	16
10	12	M12 x 1.25	4	16.7	M5 x 0.8	12	7	28	10.5	—	4.2	M4 x 0.7	19	6	11.5	9.5	15	7	16
12	16	M16 x 1.5	6	19.7	M5 x 0.8	17	8	38	14	5	6.2	M6 x 1	24	8	12.5	10.5	18.3	10	22
16	16	M16 x 1.5	6	19.7	M5 x 0.8	17	8	38	14	5	6.2	M6 x 1	24	8	12.5	10.5	18.3	10	22
20	20	M22 x 1.5	8	28	G 1/8	20	8	44	17	6	8.2	M8 x 1.25	32	11	15	15	24	13	24
25	20	M22 x 1.5	10	33.5	G 1/8	22	8	50	20	8	10.2	M10 x 1.25	32	11	15	15	30	17	28

Bore	S			Z		
	1 to 50	51 to 100	101 to 150	1 to 50	51 to 100	101 to 150
8	64.5(70.5)	—	—	92.5(98.5)	—	—
10	64.5(68.5)	—	—	92.5(96.5)	—	—
12	70(73.5)	—	—	108(111.5)	—	—
16	69(72.5)	95(98.5)	121(124.5)	107(110.5)	133(136.5)	159(162.5)
20	87	112	137	131	156	181
25	88.5	113.5	138.5	138.5	163.5	188.5

(): In the case of auto switch style.

ISO Cylinder: Standard/Non-rotating Type
Single Acting, Spring Return/Extended **Series C85**

Dimensions with Mounting Bracket

[First angle projection]

Single acting, Spring extend
Rod foot: C85L10A, C85L16A, C85L25A

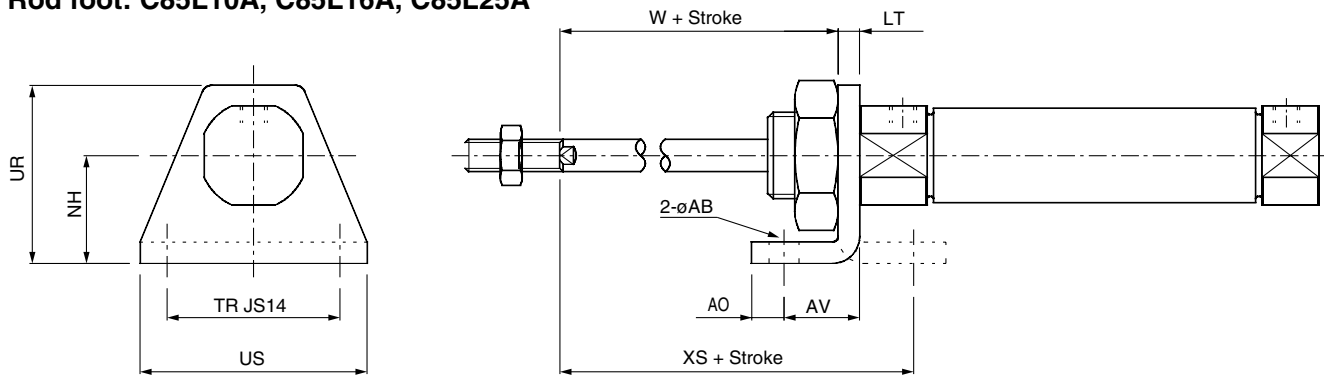

Rod flange: C85F10, C85F16, C85F25

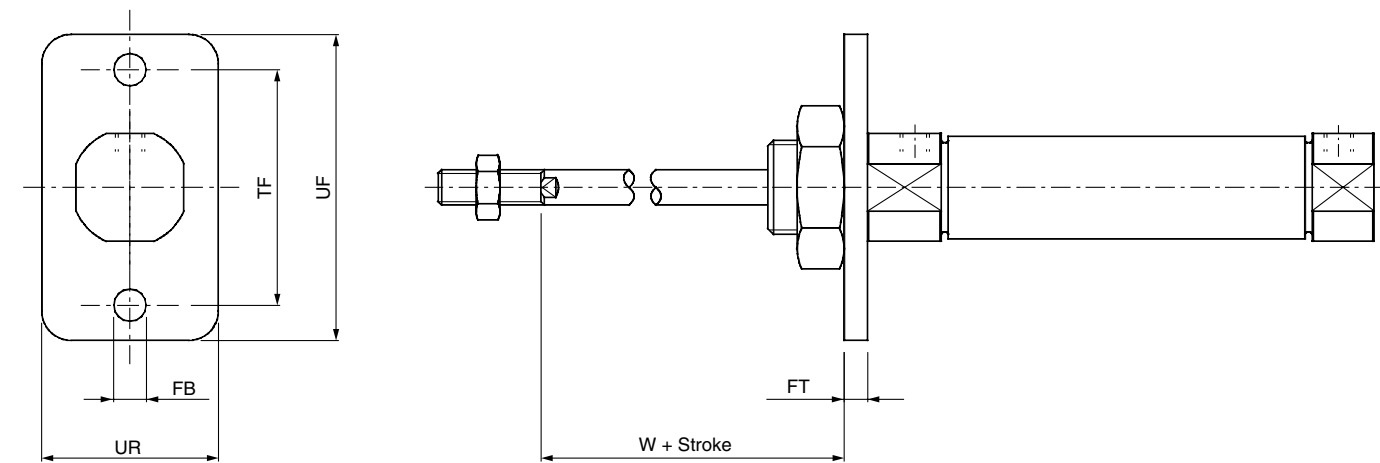

Rod trunnion: C85T10, C85T16, C85T25

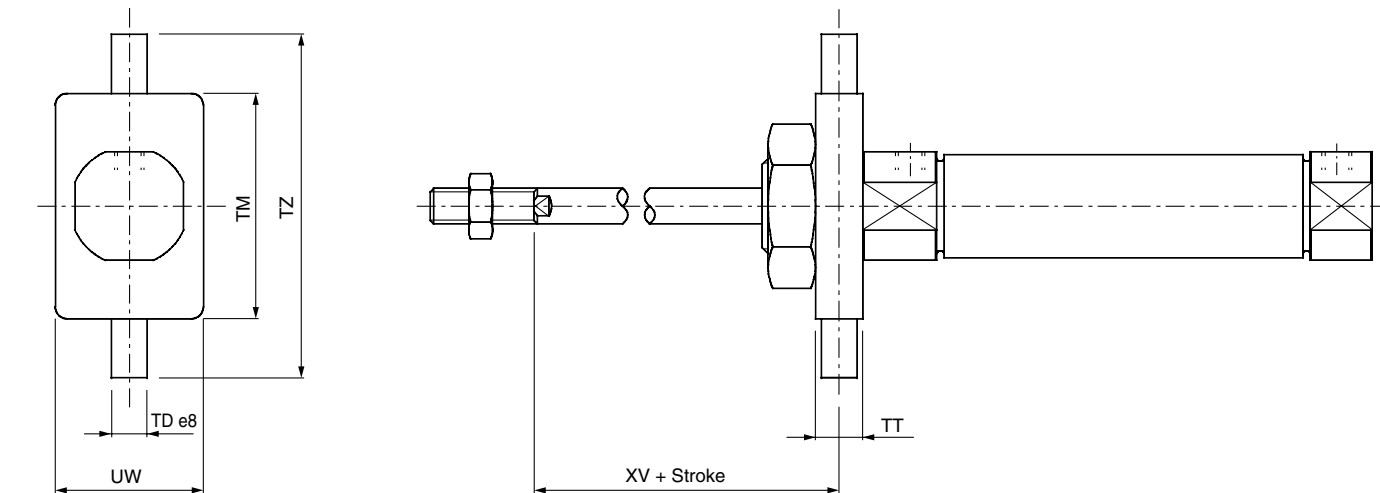

CJ1

CJP

CJ2

CM2

CG1

MB

MB1

CA2

CS1

C76

C85

C95

CP95

NCM

NCA

D-

-X

20-

Data

Bore	Rod foot										Rod flange					Rod trunnion						
	AO	US	øAB	LT	NH	TR JS14	XS	AV	UR	W	UR	FBH13	FT	TF	UF	W	TT	UW	TD e8	TM	TZ	XV
8	5	35	4.5	3.2	16	25	23.8	11	26	2.8	22	4.5	3.2	30	40	12.8	6	20	4	26	38	13
10	5	35	4.5	3.2	16	25	23.8	11	26	12.8	22	4.5	3.2	30	40	12.8	6	20	4	26	38	13
12	6	42	5.5	4	20	32	32	14	33	18	30	5.5	4	40	52	18	8	25	6	38	58	18
16	6	42	5.5	4	20	32	32	14	33	18	30	5.5	4	40	52	18	8	25	6	38	58	18
20	8	54	6.6	5	25	40	36	17	42	19	40	6.6	5	50	66	19	8	32	6	46	66	20
25	8	54	6.6	5	25	40	40	17	42	23	40	6.6	5	50	66	23	8	32	6	46	66	24

(mm)

Series C85

Auto Switch Mounting Position and Mounting Height

[First angle projection]

Single acting, Single return

(Band mounting type)

(Rail mounting type)

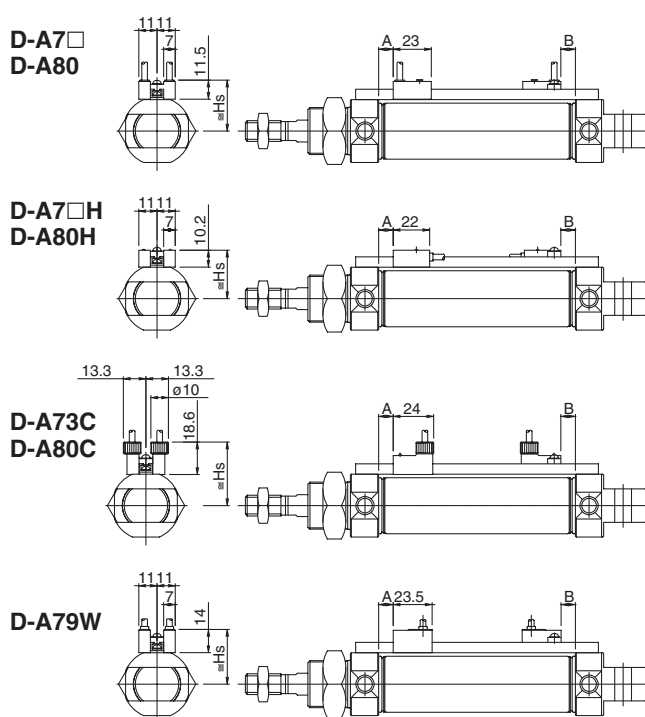
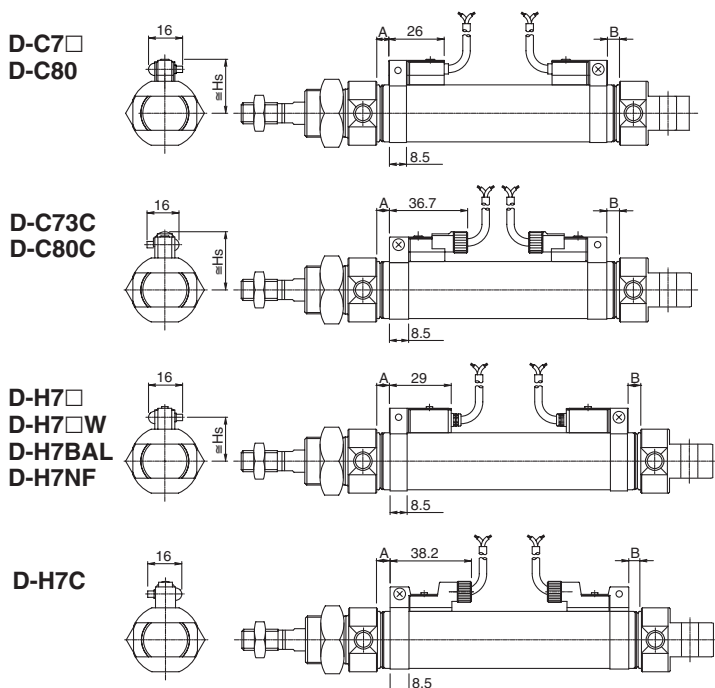

Auto Switch Mounting Position (mm)

Auto switch model	Bore	Single acting/Spring return			
		A			B
		1 to 50 st	51 to 100 st	101 to 150 st	
D-C7 D-C80 D-C73C D-C80C	8	15	15	15	3
	10	13	13	13	3
	12	14.5	14.5	14.5	4
	16	14.5	30	45.5	10
	20	7(32)	57	82	6
	25	7(32)	57	82	7.5
D-A7 D-A80	8	15.5	15.5	15.5	3.5
	10	13.5	13.5	13.5	3.5
	12	15	15	15	4.5
	16	15	30.5	45.5	10.5
	20	7.5(32.5)	57.5	82.5	6.5
	25	7.5(32.5)	57.5	82.5	8
D-A7H/A80H D-A73C/A80C D-F7/J79 D-F7W/J79W D-F7V D-F7WV D-J79C/A72 D-F7BAL D-F79F	8	16	16	16	4
	10	14	14	14	4
	12	15.5	15.5	15.5	5
	16	15.5	31	46.5	11
	20	8(33)	58	83	7
	25	8(33)	58	83	8.5
D-H7 D-H7C D-H7W D-H7BAL D-H7NF	8	14	14	14	2
	10	12	12	12	2
	12	13.5	13.5	13.5	3
	16	13.5	29	44.5	9
	20	6(31)	56	81	5
D-A79W	8	—	—	—	—
	10	—	—	—	—
	12	—	—	—	—
	16	12.5	28	43.5	8
	20	5(30)	55	80	4
D-A79W	25	5(30)	55	80	5.5

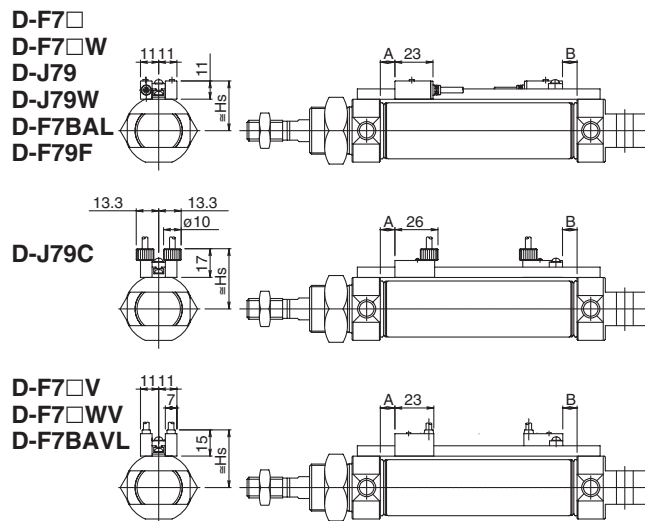

C85 Auto Switch Mounting Height

(mm)

Bore	D-C7/C80 D-H7 D-H7W D-H7BAL D-H7NF	D-C73C D-C80C	D-A7 D-A80	D-A7H/A80H D-F7/J79 D-F7W/J79W D-F7BAL D-F79F	D-A73C D-A80C	D-H7C	D-A79W	D-J79C	D-F7V D-F7WV D-F7BALV
	Hs	Hs	Hs	Hs	Hs	Hs	Hs	Hs	Hs
8	16	18.5	18	19	25	19	—	23.5	21.5
10	17	19.5	18	19	25	20	—	23.5	21.5
12	18.5	21	19.5	20.5	26.5	21	22	25	23
16	20.5	23	19.5	20.5	26.5	23	22	25	23
20	22.5	25	22.5	23.5	29.5	25	25	29	26
25	25	27.5	25.5	26.5	32.5	27.5	28	32	29

- () for non rotating type.
- The lower of $\phi 16$ is a number for CD85F/Y.
- Aim at this number.

- Aim at this number.

ISO Cylinder: Standard/Non-rotating Type Single Acting, Spring Return/Extended **Series C85**

Auto Switch Mounting Position and Mounting Height

[First angle projection]

Single acting, Single Extended

(Band mounting type)

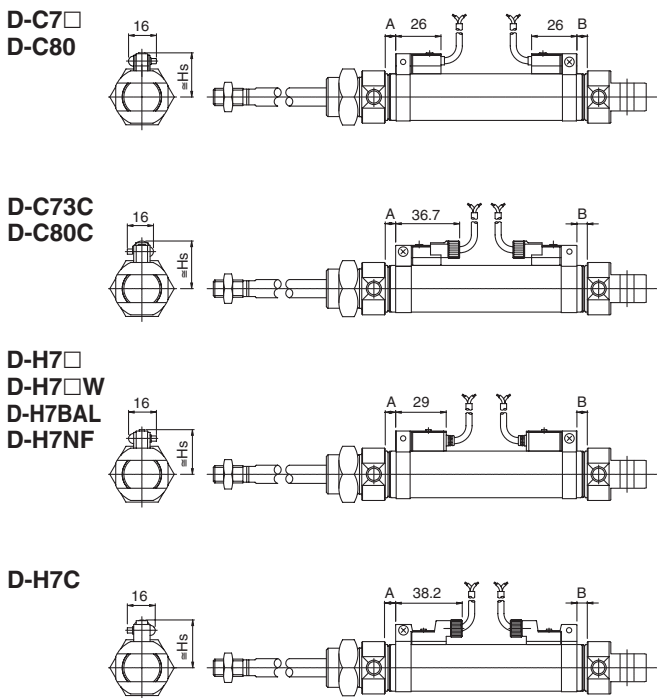

(Rail mounting type)

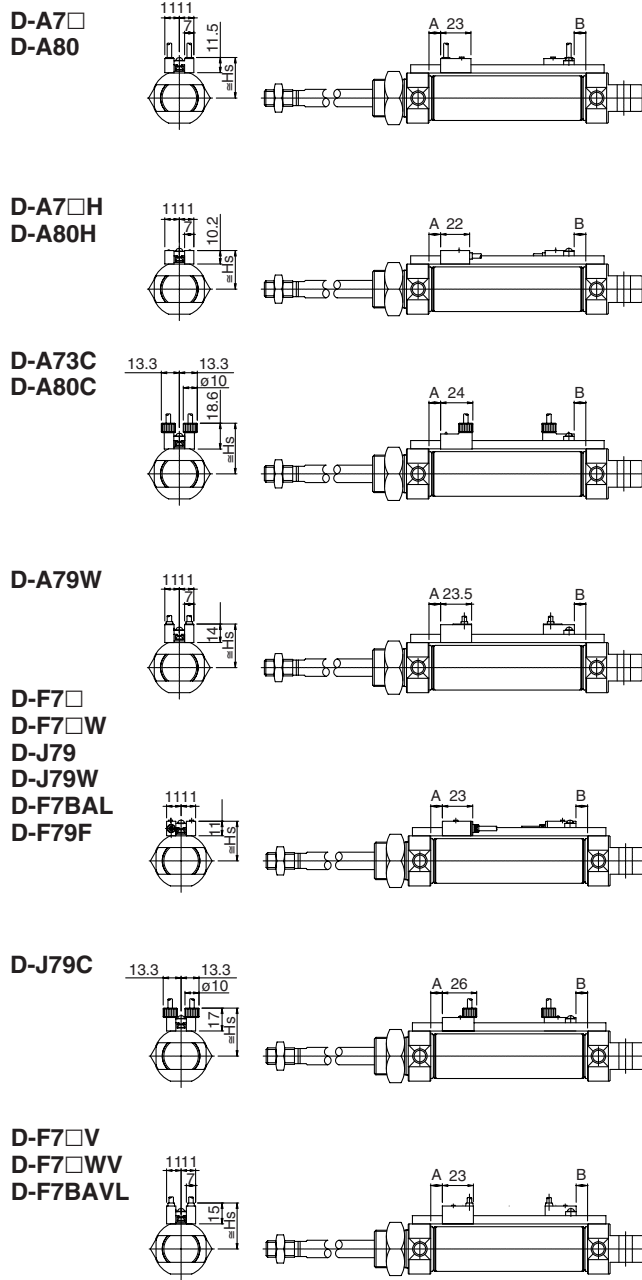

Auto Switch Mounting Position (mm)

Auto switch model	Bore	Single acting/Spring extended			
		A	B		
			1 to 50 st	51 to 100 st	101 to 150 st
D-C7□ D-C80 D-C73C D-C80C	8	3	27.5	27.5	27.5
	10	3	25.5	25.5	25.5
	12	4	27.5	27.5	27.5
	16	4	32.5	58.5	84.5
			26.5	52.5	78.5
	20	7	31	56	81
D-A73 D-A80	8	3.5	28	28	28
	10	3.5	26	26	26
	12	4.5	28	28	28
	16	4.5	33	59	85
			27	53	79
	20	7.5	31.5	56.5	81.5
D-A7□H/A80H D-A73C/A80C D-F7□/J79 D-F7□W/J79W D-F7□V D-F7□WV D-J79C/A72 D-F7BAL D-F79F	8	4	28.5	28.5	28.5
	10	4	26.5	26.5	26.5
	12	5	28.5	28.5	28.5
	16	5	33.5	59.5	85.5
			27.5	53.5	79.5
	20	8	32	57	82
D-H7□ D-H7C D-H7□W D-H7BAL D-H7NF	8	2	27.5	27.5	27.5
	10	2	25.5	25.5	25.5
	12	3	27.5	27.5	27.5
	16	3	32.5	58.5	84.5
			26.5	52.5	78.5
	20	6	31	56	81
D-A79W	8	1	—	—	—
	10	1	—	—	—
	12	2	—	—	—
	16	2	3.5	56.5	82.5
			24.5	50.5	76.5
	20	5	29	54	79

C85 Auto Switch Mounting Height

Bore	D-C7□/C80 D-H7□ D-H7□W D-H7BAL D-H7NF	D-C73C D-C80C	D-A7□ D-A80	D-A7□H/A80H D-F7□/J79 D-F7□W/J79W D-F7BAL D-F79F	D-A73C D-A80C	D-H7C	D-A79W	D-J79C	D-F7□V D-F7□WV D-F7BAVL
	Hs	Hs	Hs	Hs	Hs	Hs	Hs	Hs	Hs
8	16	18.5	18	19	25	19	—	23.5	21.5
10	17	19.5	18	19	25	20	—	23.5	21.5
12	18.5	21	19.5	20.5	26.5	21	22	25	23
16	20.5	23	19.5	20.5	26.5	23	22	25	23
20	22.5	25	22.5	23.5	29.5	25	25	29	26
25	25	27.5	25.5	26.5	32.5	27.5	28	32	29

• Aim at this number.

- CJ1
- CJP
- CJ2
- CM2
- CG1
- MB
- MB1
- CA2
- CS1
- C76
- C85**
- C95
- CP95
- NCM
- NCA
- D-
- X
- 20-
- Data

ISO Cylinder: Direct Mount Type

Double Acting, Single Rod

Series C85R

ø8, ø10, ø12, ø16, ø20, ø25

How to Order

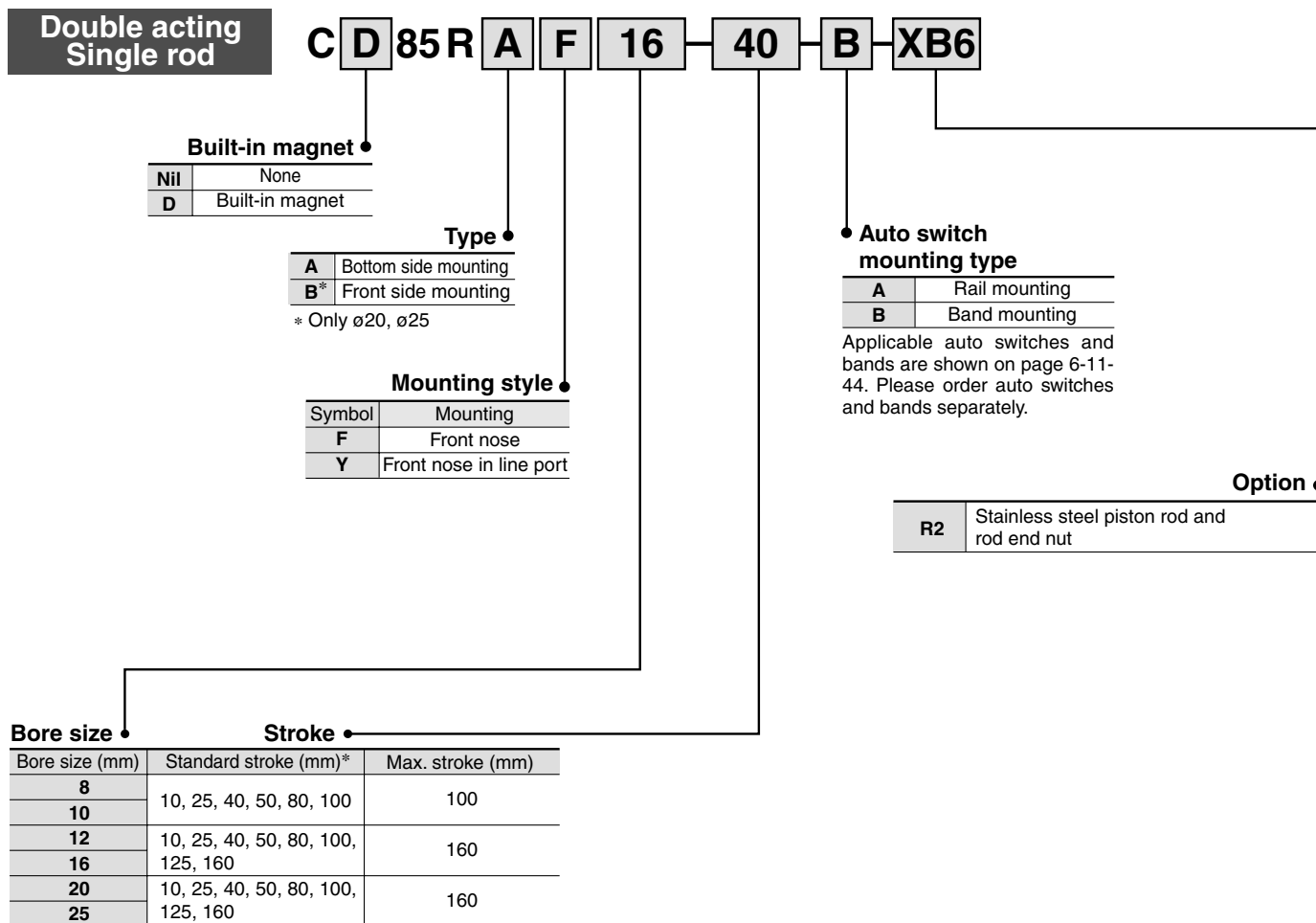

* Other strokes on request.

Mounting Bracket Part No.

Mounting bracket	Bore size (mm)					
	8	10	12	16	20	25
Single knuckle joint	KJ4D		KJ6D		KJ8D	KJ10D
Double knuckle joint	GKM4-8		GKM6-10		GKM8-16	GKM10-20
Floating joint	JA10-4-070		JA15-6-100		JA20-8-125	JA30-10-125

Replacement Parts

Bore size (mm)	Part no.	Note
20	C85-20PS	Every set includes: n°1 rod seal n°1 seal retaining washer n°1 retaining ring
25	C85-25PS	

ISO Cylinder: Direct Mount Type Double Acting, Single Rod **Series C85R**

Square rod cover makes direct mounting possible

Space-saving

Mounting accuracy and rigidity made possible by means of faucet joint and direct mounting.

Front nose mounting type and bottom side mounting available to suit your applications.

Bottom side mounting

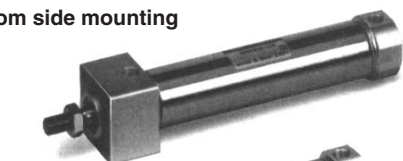

Front side mounting

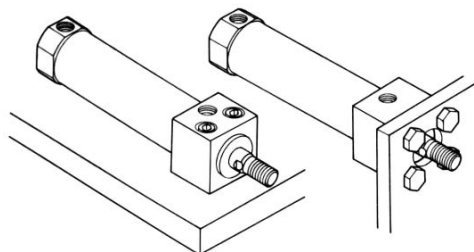

Bottom side mounting

Front side mounting

JIS Symbol

Double Acting, Single Rod

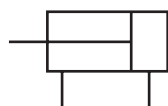

Specifications

Bore size (mm)	8	10	12	16	20	25
Piston rod dia. (mm)	4	4	6	6	8	10
Piston rod thread	M4 x 0.7	M4 x 0.7	M6 x 1	M6 x 1	M8 x 1.25	M10 x 1.25
Port size	M 5 x 0.8	M 5 x 0.8	M 5 x 0.8	M 5 x 0.8	G 1/8	G 1/8
Action	Double acting, Single rod					
Fluid	Air					
Proof pressure	1.5 MPa					
Max. operating pressure	1.0 MPa					
Min. operating pressure	0.1 MPa	0.08 MPa		0.05 MPa		
Ambient and fluid temperature	-20 to 80°C (Built-in magnet type: -10 to 60°C)					
Cushion	Rubber bumper (Standard)					
Lubrication	Not required. Use turbine oil Class 1 ISO VG32, if lubricated.					
Piston speed	50 to 1500 mm/s					
Allowable kinetic energy	0.02 J	0.03 J	0.04 J	0.09 J	0.27 J	0.4 J
Stroke tolerance	0/+1			0/+1.4		

Weight

Bore size (mm)		8	10	12	16	20	25
Basic weight	Bottom side mounting	43	46	84	95	167	253
	Front side mounting	—	—	—	—	163	230
Additional weight for each 10 mm of stroke		2	2.2	4.1	5.1	7.8	12.2

CJ1

CJP

CJ2

CM2

CG1

MB

MB1

CA2

CS1

C76

C85

C95

CP95

NCM

NCA

D-

-X

20-

Data

Series C85R

Auto Switch Mounting, Minimum Possible Cylinder Stroke

Band Mounting Style

Bore size: ø8, ø10, ø12, ø16

(mm)

Auto switch model	No. of auto switches				1 pc.
	3 pcs.		2 pcs.		
	Different sides	Same side	Different sides	Same side	
D-C7□ D-C80	55	90	15	50	10
D-C73C D-C80C D-H7C	65	105	15	65	10
D-H7□ D-H7□W D-H7BAL D-H7NF	60	105	15	60	10

Rail Mounting Style

Bore size: ø8, ø10, ø12, ø16

(mm)

Auto switch model	No. of auto switches		1 pc.
	3 pcs.	2 pcs.	
	D-A7□/A80 D-A73C/A80C	35	
D-A7□H D-A80H	45	10	5
D-A79W *	40	15	10
D-F7□ D-J79	45	5	5
D-F7□V D-J79C	30	5	5
D-F7□W D-J79W D-F7BAL D-F79F	55	15	10
D-F7□WV D-F7BAVL	40	15	10

* "D-A79W" cannot be mounted on bore size ø8, ø10, ø12 cylinder.

Band Mounting Style

Bore size: ø20, ø25

(mm)

Auto switch model	No. of auto switches				1 pc.
	2 pcs.		n pcs.		
	Different sides	Same side	Different sides	Same side	
D-C7□ D-C80	15	50	$15 + 45 \binom{n-2}{2}$ (n = 2, 4...)	$50 + 45(n-2)$	10
D-C73C D-C80C D-H7C	15	65	$15 + 45 \binom{n-2}{2}$ (n = 2, 4...)	$65 + 50(n-2)$	10
D-H7□ D-H7□W D-H7BAL D-H7NF	15	60	$15 + 45 \binom{n-2}{2}$ (n = 2, 4...)	$60 + 55(n-2)$	10

Rail Mounting Style

Bore size: ø20, ø25

(mm)

Auto switch model	No. of auto switches		1 pc.
	2 pcs.	n pcs.	
	D-A7□/A80 D-A7□H/A80H D-A73C/A80C D-F7□ D-F7□V D-J79 D-J79C	10	
D-A79W D-F7□W D-J79W D-F7BAL D-F79F D-F7□WV D-F7BAVL	15	$15 + 35 \binom{n-2}{2}$ (n = 2, 4...)	10

ISO Cylinder: Direct Mount Type Double Acting, Single Rod **Series C85R**

Construction

[First angle projection]

Double acting, Single rod
C□85RA8 to 16 (Disassembly is not possible.)

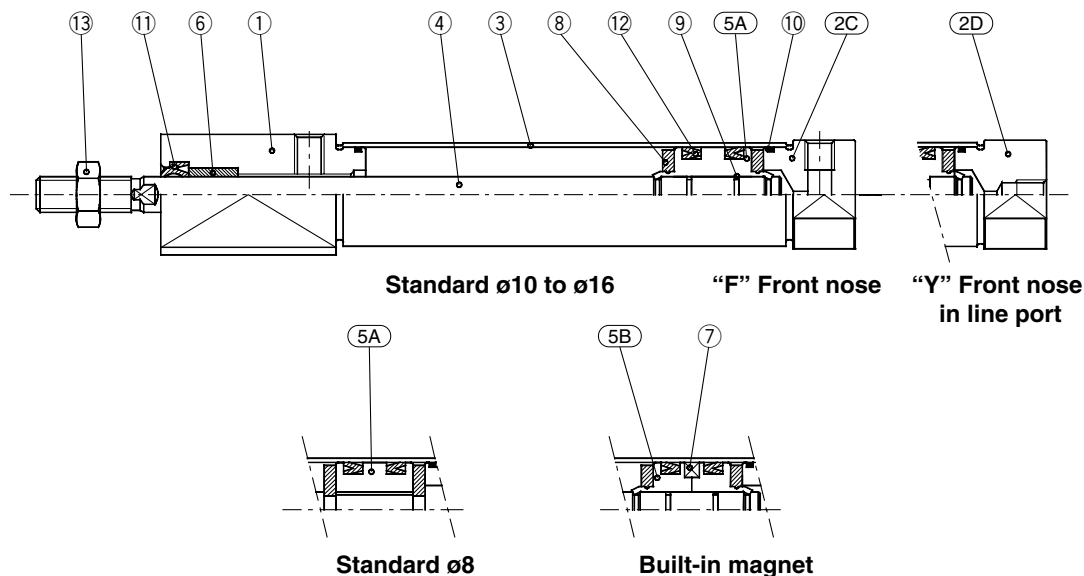

Component Parts

No.	Description	Material	Qty.	Note
①	Rod cover	Aluminum alloy	1	White anodized
②C	Head cover F	Aluminum alloy	1	White anodized
②D	Head cover Y	Aluminum alloy	1	White anodized
③	Cylinder tube	Stainless steel	1	
④	Piston rod	Stainless steel	1	
⑤A	Piston "A"	Brass	1	
⑤B	Piston "B"	Brass	2	(Switch type piston)

No.	Description	Material	Qty.	Note
⑥	Bush	Sintered bronze	1	
⑦	Magnet	Magnet	1	(Switch type only)
⑧	Bumper	Urethane	2	
⑨	Piston gasket	NBR	1	(2 for switch type)
⑩	Tube gasket	NBR	2	
⑪	Rod seal	NBR	1	
⑫	Piston seal	NBR	2	
⑬	Rod end nut	Carbon steel	1	Nickel plating

C□85R□20/25

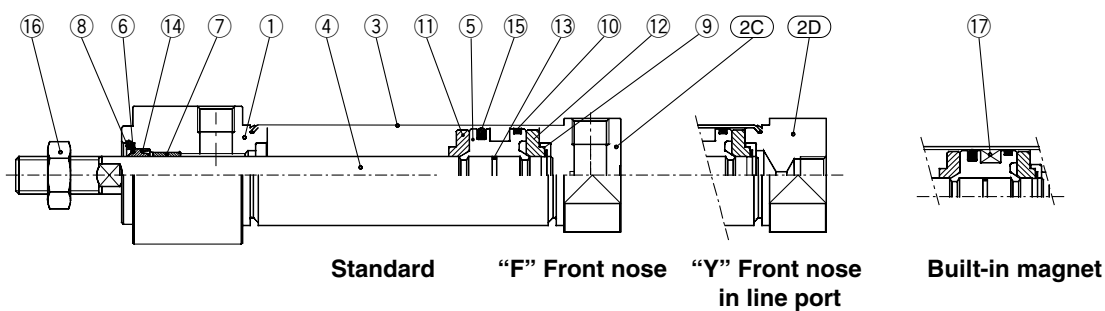

Component Parts

No.	Description	Material	Qty.	Note
①	Rod cover	Aluminum alloy	1	White anodized
②C	Head cover F	Aluminum alloy	1	White anodized
②D	Head cover Y	Aluminum alloy	1	White anodized
③	Cylinder tube	Stainless steel	1	
④	Piston rod	Carbon steel	1	Hard chrome plated
⑤	Piston	Aluminum alloy	1	Chromate
⑥	Plain washer	Stainless steel	1	
⑦	Bush	Sintered bronze	1	
⑧	Retaining ring	Carbon steel	1	Nickel plating

No.	Description	Material	Qty.	Note
⑨	Retaining ring	Stainless steel	1	
⑩	Wear ring	Resin	1	
⑪	Bumper A	Urethane	1	
⑫	Bumper B	Urethane	1	
⑬	Piston gasket	NBR	1	
⑭	Rod seal	NBR	1	
⑮	Piston seal	NBR	1	
⑯	Rod end nut	Carbon steel	1	Nickel plating
⑰	Magnet	Magnet	1	(Switch type only)

- CJ1
- CJP
- CJ2
- CM2
- CG1
- MB
- MB1
- CA2
- CS1
- C76
- C85**
- C95
- CP95
- NCM
- NCA
- D-
- X
- 20-
- Data

Series C85R

Dimensions

[First angle projection]

Double acting, Single rod
 Base mounting/C□85RA_F 8 to 16 — Stroke — B
 Without magnet, Built-in magnet (Band mounting type)

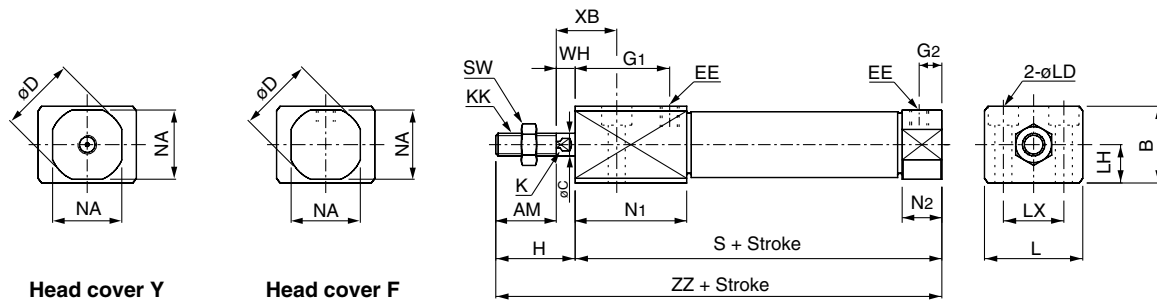

Bore	AM	B	øC	øD	EE	G1	G2	H	K	KK	L	øLD	LH	LX	N1	N2	NA	S	SW	WH	XB	ZZ
8	12	16	4	17	M5 x 0.8	19	5	16	—	M4 x 0.7	23	ø3.5, ø6.5 depth of counterbore 4	8	14	23.5	9.5	15	58	7	4	12	74
10	12	16	4	17	M5 x 0.8	19	5	16	—	M4 x 0.7	23	ø3.5, ø6.5 depth of counterbore 4	8	14	23.5	9.5	15	58	7	4	12	74
12	16	20	6	20	M5 x 0.8	25	6	21	5	M6 x 1	26	ø4.5, ø8 depth of counterbore 5	10	16	29.5	10.5	18.3	67	10	5	16	88
16	16	20	6	20	M5 x 0.8	25	6	21	5	M6 x 1	26	ø4.5, ø8 depth of counterbore 5	10	16	29.5	10.5	18.3	67	10	5	16	88

Base mounting/C□85RA_F 20/25 — Stroke — B
 Without magnet, Built-in magnet (Band mounting type)

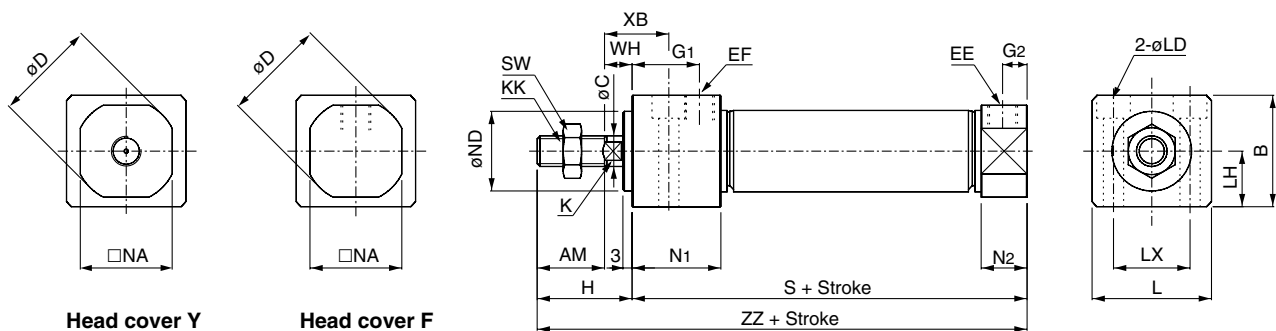

Bore	AM	B	øC	øD	EE	G1	G2	H	K	KK	L	øLD	LH	LX	N1	N2	□NA	øND h8	S	SW	WH	XB	ZZ
20	20	30.3	8	28	G 1/8	22	8	30	6	M8 x 1.25	33.5	ø5.5, ø9.5 depth of counterbore 6.5	15	21	29	15	24	20 ⁰ _{-0.033}	76	13	10	22	106
25	22	36.6	10	33.5	G 1/8	22	8	36	8	M10 x 1.25	39	ø6.6, ø11 depth of counterbore 7.5	18	25	29	15	30	26 ⁰ _{-0.033}	79	17	14	26	115

Front mounting/C□85RB_F 20/25 — Stroke — B
 Without magnet, Built-in magnet (Band mounting type)

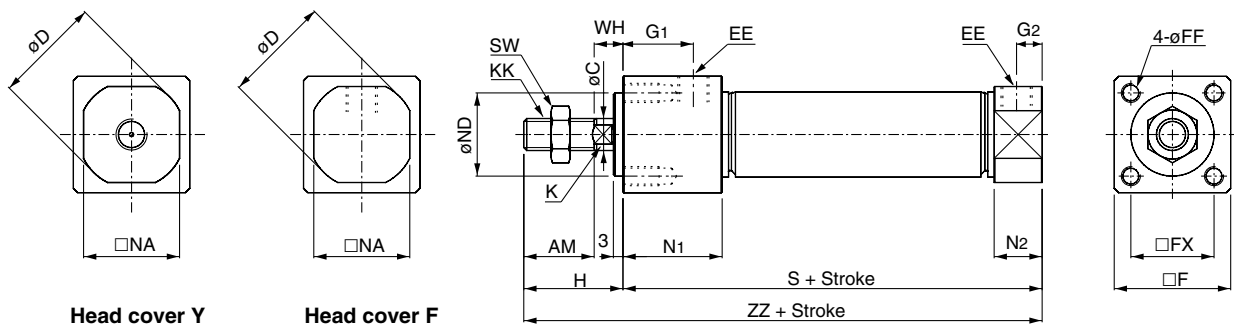

Bore	AM	øC	øD	EE	□F	FF	□FX	G1	G2	H	K	KK	N1	N2	□NA	øND h8	S	SW	WH	ZZ
20	20	8	28	G 1/8	30.4	M5 x 0.8 depth 9	22	22	8	30	6	M8 x 1.25	29	15	24	20 ⁰ _{-0.033}	76	13	10	106
25	22	10	33.5	G 1/8	36.4	M6 x 1 depth 11	26	22	8	36	8	M10 x 1.25	29	15	30	26 ⁰ _{-0.033}	79	17	14	115

ISO Cylinder: Direct Mount Type Double Acting, Single Rod **Series C85R**

Auto Switch Mounting Position and Mounting Height

[First angle projection]

Double acting, Single rod

(Band mounting type)

(Rail mounting type)

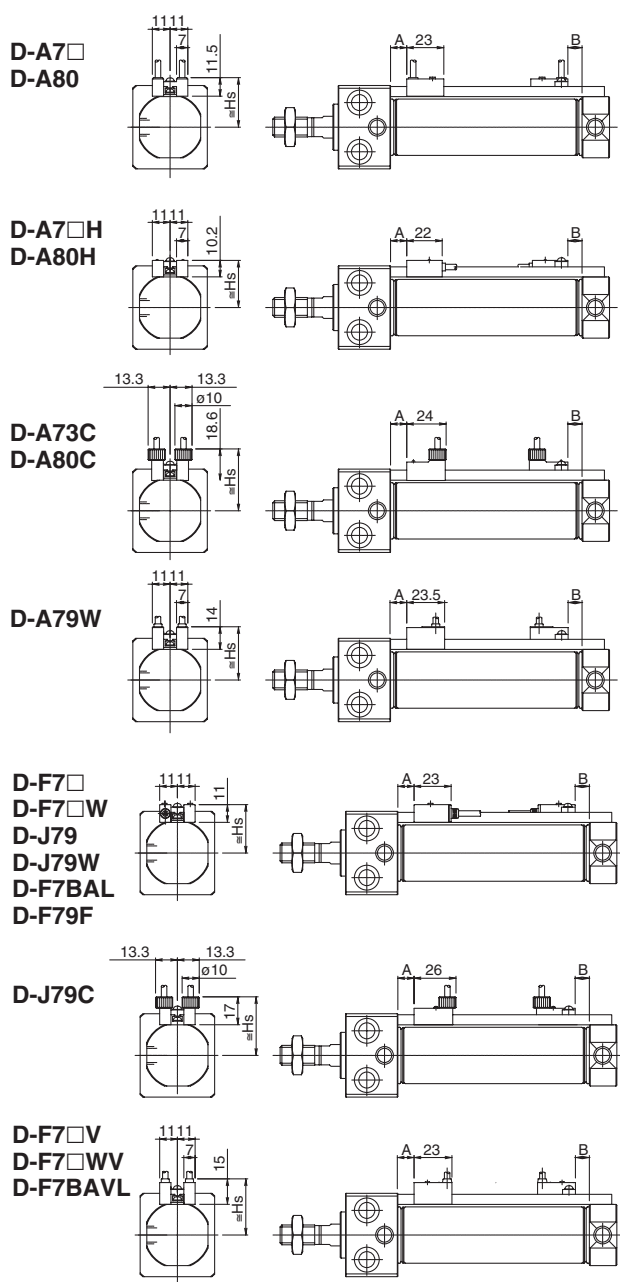
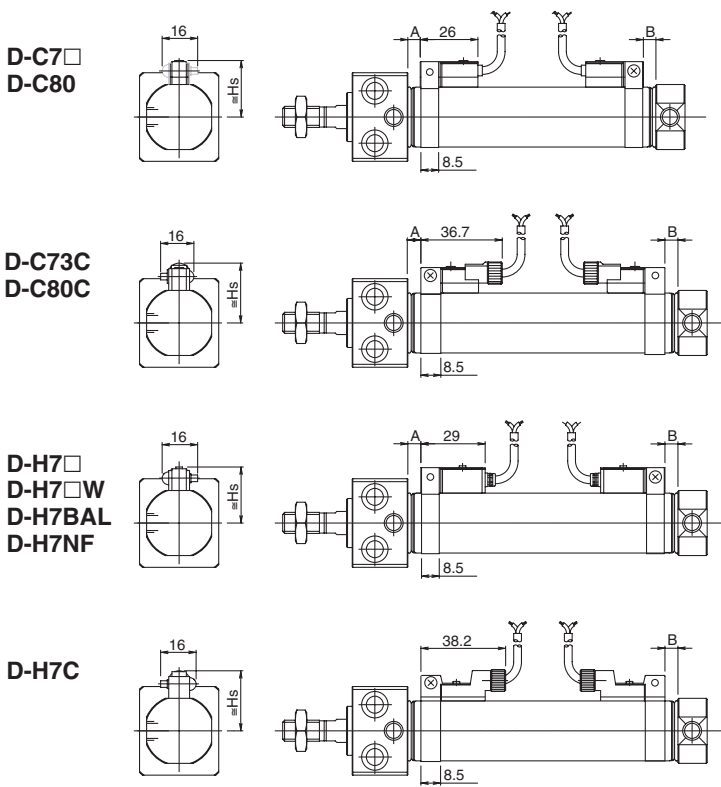

Auto Switch Mounting Position

(mm)

Bore	D-C7□ D-C80 D-C73C D-C80C		D-A73 D-A80		D-A7□H/A80H D-A73C/A80C D-F7□/J79 D-F7□W/J79W D-F7□V D-F7□WV D-J79C/A72 D-F7BAL D-F79F		D-H7□ D-H7C D-H7□W D-H7BAL D-H7NF		D-A79W	
	A	B	A	B	A	B	A	B	A	B
8	3	3	3.5	3.5	4	4	2	2	—	—
10	3	3	3.5	3.5	4	4	2	2	—	—
12	4	4	4.5	4.5	5	5	3	3	—	—
16	4	4	4.5	4.5	5	5	3	3	2	2
20	7	6	7.5	6.5	8	7	6	5	5	4
25	8.5	7.5	9	8	9.5	8.5	7.5	6.5	6.5	5.5

C85 Auto Switch Mounting Height

(mm)

Bore	D-C7□/C80 D-H7□ D-H7□W D-H7BAL D-H7NF	D-C73C D-C80C	D-A7□ D-A80	D-A7□H/A80H D-F7□/J79 D-F7□W/J79W D-F7BAL D-F79F	D-A73C D-A80C	D-H7C	D-A79W	D-J79C	D-F7□V D-F7□WV D-F7BAVL
	Hs	Hs	Hs	Hs	Hs	Hs	Hs	Hs	Hs
8	16	18.5	18	19	25	19	—	23.5	21.5
10	17	19.5	18	19	25	20	—	23.5	21.5
12	18.5	21	19.5	20.5	26.5	21	—	25	23
16	20.5	23	19.5	20.5	26.5	23	22	25	23
20	22.5	25	22.5	23.5	29.5	25	25	29	26
25	25	27.5	25.5	26.5	32.5	27.5	28	32	29

• Aim at this number.

- CJ1
- CJP
- CJ2
- CM2
- CG1
- MB
- MB1
- CA2
- CS1
- C76
- C85**
- C95
- CP95
- NCM
- NCA
- D-
- X
- 20-
- Data

Series C85

Applicable Auto Switch

Type	Special function	Electrical entry	Indicator light	Wiring (Output)	Load voltage		Auto switch model**			Lead wire length* (mm)				Applicable load		
					DC	AC	Band mounting	Rail mounting		0.5 (—)	3 (L)	5 (Z)	None (N)	IC circuit	—	
								Perpendicular	In-line							
Reed switch	—	Grommet	Yes	3-wire (NPN)	—	5 V	—	C76	—	A76H	●	●	—	—	IC circuit	—
				2-wire	24 V	—	—	200 V	—	A72	A72H	●	●	—	—	—
		12 V	100 V			C73	A73	A73H	●	●	●	—	—	—	—	
		5 V, 12 V	≤ 100 V			C80	A80	A80H	●	●	—	—	IC circuit	—		
		Connector	Yes	12 V	—	C73C	A73C	—	●	●	●	●	—	—	—	—
	No	5 V, 12 V	≤ 24 V	C80C	A80C	—	●	●	●	●	—	—	IC circuit	—		
Diagnostic indication (2-color)	Grommet	Yes	—	—	—	—	A79W	—	●	●	—	—	—	—	—	
Solid state switch	—	Grommet	—	3-wire (NPN)	5 V, 12 V	—	—	H7A1	F7NV	F79	●	●	○	—	IC circuit	Relay, PLC
				3-wire (PNP)				H7A2	F7PV	F7P	●	●	○	—	—	
		2-wire	12 V	—	H7B	F7BV	J79	●	●	○	—	—				
		2-wire			H7C	J79C	—	●	●	●	●	—	—			
	Diagnostic indication (2-color)	Grommet	Yes	3-wire (NPN)	24 V	5 V, 12 V	—	—	H7NW	F7NWV	F79W	●	●	○	—	IC circuit
									3-wire (PNP)	H7PW	—	F7PW	●	●	○	—
	Water resistant (2-color)	Grommet	—	2-wire	12 V	—	—	—	H7BA	F7BAV	F7BA	—	●	○	—	—
									3-wire (NPN)	—	—	F7NT	●	●	○	—
	With timer	Grommet	—	4-wire (NPN)	5 V, 12 V	—	—	—	H7NF	—	F79F	●	●	○	—	IC circuit
	With diagnostic output (2-color)								—	—	—	—	—	—	—	—

* Lead wire length symbols: 0.5 m Nil (Example) C73C
 5 m Z (Example) C73CZ
 3 m L (Example) C73CL
 None N (Example) C73CN

* Solid state switches marked with "○" are manufactured upon receipt of order.

** "D-A79W" cannot be mounted on bore size ø8, ø10, ø12 cylinder.

Mounting Bracket Band mounting type

<Applicable auto switch>

D-C7□/C80, D-C73C/C80C, D-H7□, D-H7C

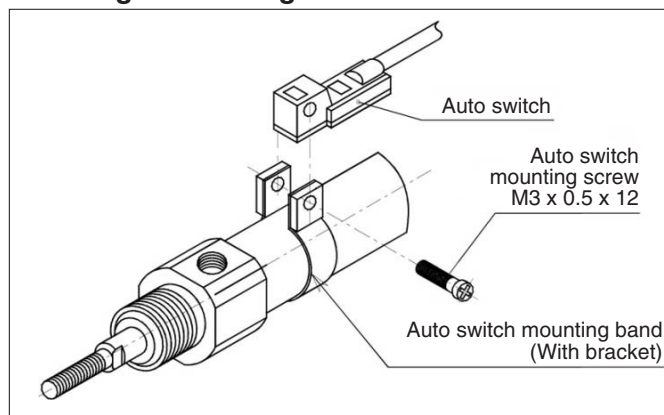
Mounting and Moving Method of Auto Switch

1. Put a mounting band on the cylinder tube and position the auto switch.
2. Put the mounting part of auto switch in the middle of the stationary fitting, aligning the mounting hole with the hole of the stationary fitting.
3. Screw in the auto switch mounting screw through the mounting hole into the threaded part of the band fitting.
4. Set the whole body to the detecting position by sliding, then tighten the mounting screw to fix the auto switch (the tightening torque of M3 screw should be about 80 to 100 N/cm).
5. Modification of the detecting position should be made following step #3.

Auto Switch Mounting Band Part No.

Series	Bore size (mm)					
	8	10	12	16	20	25
C85	BJ2-008	BJ2-010	BJ2-012	BJ2-016	BM2-020	BM2-025

Differential Response of Auto Switch

The distance from the operating position of auto switch to the returning position is called the differential response. This response is included in part of the operating range (one side).

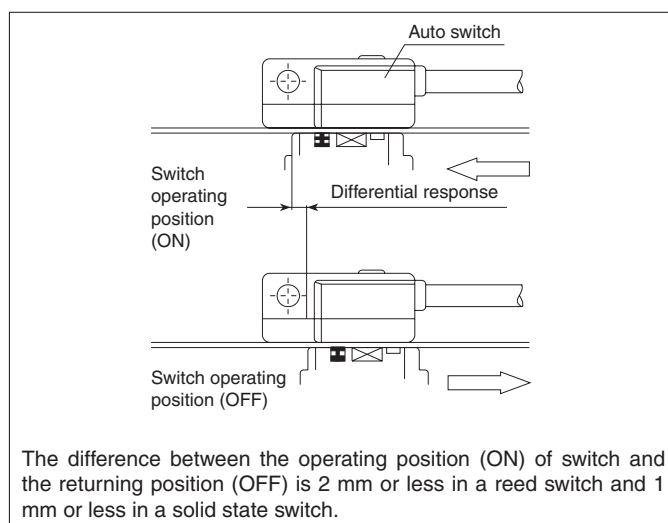

The difference between the operating position (ON) of switch and the returning position (OFF) is 2 mm or less in a reed switch and 1 mm or less in a solid state switch.

Mounting Bracket Rail mounting type

<Applicable auto switch>

D-A7□/A80, D-A73C/A80C, D-F7□/J7□, D-J79C

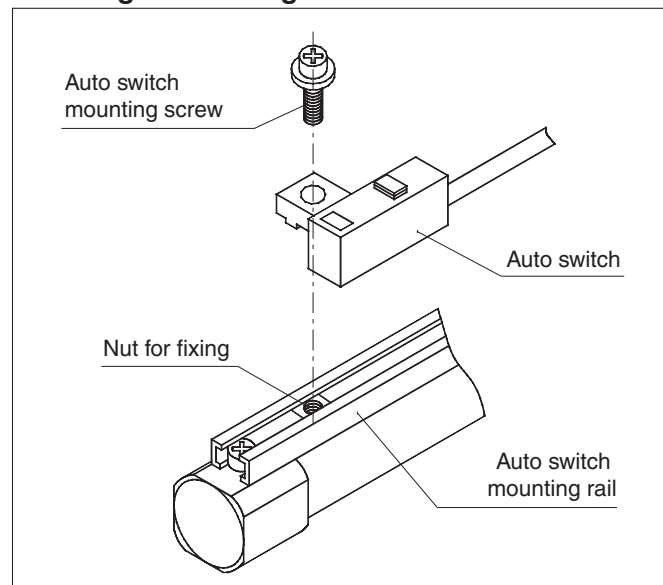
Mounting and Moving Method of Auto Switch

1. Slide the nut located inside the mounting rail and set it at the auto switch mounting position.
2. Fit the convex part of the auto switch mounting arm into the slot of the rail and slide it to the nut position.
3. Allow the auto switch mounting screw to match gently in the nut for attachment and screw it in.
4. Check the detecting position again and tighten the mounting screw to fix the auto switch definitely (the tightening torque of M3 screw should be about 50 to 70 N/cm).
5. Modification of the detecting position should be made following step #3.

Maximum Piston Speed

If an auto switch is set at mid-stroke, the electrical device to which it is connected, may not operate if piston speed is too high. Maximum allowable piston speed "V" is given by

$$V \text{ (mm/s)} = \frac{\text{Operating range of auto switch (mm)}}{\text{Response time of electrical device (ms)}} \times 1000$$

Example

The operating range of a D-A73L reed switch on a CD85E40 cylinder is 8 mm. It is necessary to use a solenoid valve with an electrical response time of 30 ms.

$$\text{Maximum piston speed, } V = \frac{8}{30} \times 1000 = 266 \text{ mm/s}$$

Operating Range of Auto Switch

Mounting	Model	Bore size (mm)					
		8	10	12	16	20	25
Band	D-C7□/C80/C73C/C80C	7	7	7	7	7	8
	D-H7□/H7□W/H7BAL	3	3	3	4	4	4
	D-H7C	8	8	8	9	7	8.5
Rail	D-A7□/A80, D-A7□H/A80	8	8	9	9	7	7
	D-A73C/A80C	—	—	—	13	10.5	10.5
	D-A79W	—	—	—	13	10.5	10.5
	D-F7□/J79/F7□W/J79W	—	—	—	13	10.5	10.5
	D-F7□V/F7□WV/F79F	5	5	6	6	5	6
	D-J79C/F7BA□	—	—	—	—	—	—

CJ1

CJP

CJ2

CM2

CG1

MB

MB1

CA2

CS1

C76

C85

C95

CP95

NCM

NCA

D-

-X

20-

Data

Series C85

Contact Protective Box CD-P11, CD-P12

D-A7/A8 and D-C7/C8 reed switches do not incorporate contact protection circuits. Contact protection is required if:

1. Operating load is inductive.
2. The wiring length to load is 5 m or more.
3. Load voltage is 100 VAC or more.

Contact Protective Box/Specifications

Part no.	CD-P11		CD-P12
Load voltage	100 VAC	200 VAC	24 VDC
Max. load current	25 mA	12.5 mA	50 mA

Lead wire length Switch connecting side 0.5 m
Load connecting side 0.5 m



Connection Method of Contact Protector

Connect lead wires from reed switch to those on protector box indicated with "switch". Length of lead between switch body and protector should be less than 1 m.

Contact Protective Box/Internal Circuit

CD-P11

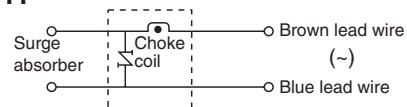

CD-P12

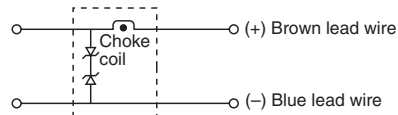

Contact Protective Box/Dimensions

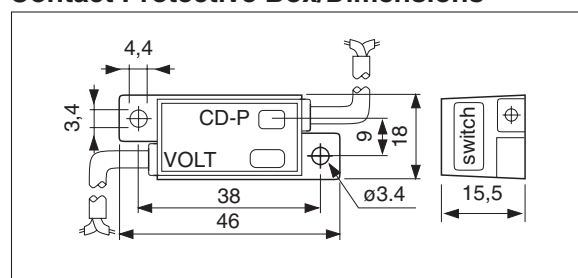

1 High Temperature XB6**C85 Mounting Bore size – Stroke – XB6**

N, E, F, Y 8, 10, 12, 16, 20, 25 mm

Standard cylinder seals are replaced with special ones and other modifications are made in order to enable the cylinder to operate at a high ambient temperature (–10 to 150°C).

Possible applications:

- Bore size 8 to 20 mm
- Rubber bumper
- Without magnets (Auto switches cannot be used at high temperature.)
- Single rod — Double acting
- Double rod — Double acting (W)

Dimensions unchanged**Specifications**

Type	Air cylinder
Applicable size	ø8, ø10, ø16, ø20, ø25 mm
Action	Double acting
Ambient temperature range	–10 to 150°C
Piston speed	50 to 500 mm/s
Cushion	Rubber bumper
Material	Seal: Fluorocarbon rubber Wear ring: Fluorocarbon resin
Grease	Fluorinated grease

Note) Contact SMC for non-rotating type.

3 Low Speed XB9**C85 Mounting Bore size – Stroke – XB9**

N, E, F, Y 20, 25 mm

The cylinder does not generate any stick-slip phenomenon even at the rated low speed of 10 to 50 mm/s.
All strokes drive at a constant speed smoothly.

Possible applications:

- Bore size 20 and 25 mm
- Rubber bumper type only
- With or without magnets
- Single rod — Double acting

Dimensions unchanged**Specifications**

Type	Air cylinder
Applicable size	ø20, ø25 mm
Action	Double acting
Piston speed	10 to 50 mm/s
Cushion	Rubber bumper

Note) Contact SMC for non-rotating type.

2 Low Temperature XB7**C85 Mounting Bore size – Stroke – XB7**

N, E, F, Y 20, 25 mm

Standard cylinder packing are replaced with special ones and other modifications are made in order to enable the cylinder to operate at a low ambient temperature (–55 to 70°C).

Possible applications:

- Bore size 20 and 25 mm
- Rubber bumper
- Without magnets (Auto switches cannot be used at low temperature.)
- Single rod — Double acting
- Double rod — Double acting (W)

Dimensions unchanged**Specifications**

Type	Air cylinder
Applicable size	ø20, ø25 mm
Action	Double acting
Ambient temperature range	–55 to 70°C
Cushion	Rubber bumper
Material	Seal: Low nitrile rubber Wear ring: Fluorocarbon resin
Grease	Fluorinated grease

Note) Contact SMC for non-rotating type.

4 Heavy-duty Scraper XC4**C85 Mounting Bore size – Stroke – XC4**

N, E, F, Y 20, 25 mm

A heavy-duty scraper is used as wiper ring. Ideal for severe applications where the cylinder is exposed to dust, earth and sand. Applicable to casting machines, construction machines, industrial vehicles, etc.

Possible applications:

- Bore size 20 and 25 mm
- Rubber bumper type only
- With or without magnets
- Single rod — Double acting
- Double rod — Double acting (W)

Dimensions unchanged**Specifications**

Type	Air cylinder
Applicable size	ø20, ø25 mm
Max. operating pressure	1 MPa (10 bar)
Min. operating pressure	0.08 MPa (0.8 bar)
Cushion	Rubber bumper
Wiper ring	NBR (SCB)

Note) Not applicable for non-rotating type.

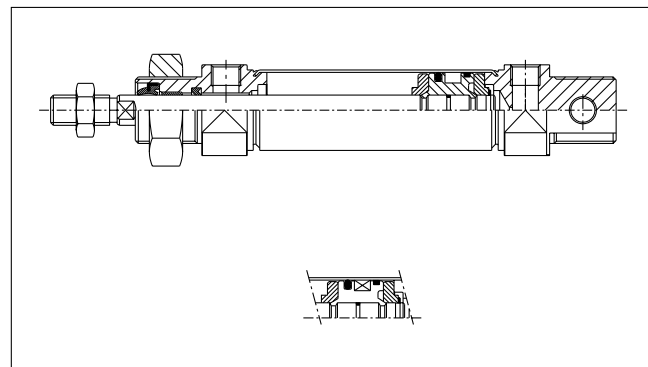
Construction

CJ1

CJP

CJ2

CM2

CG1

MB

MB1

CA2

CS1

C76

C85

C95

CP95

NCM

NCA

D-

-X

20-

Data